

JVC

English

中文

MICRO COMPONENT SYSTEM

微型组合音响

UX-H10

—Consists of CA-UXH10 and SP-UXH10
—由 CA-UXH10 及 SP-UXH10 组成

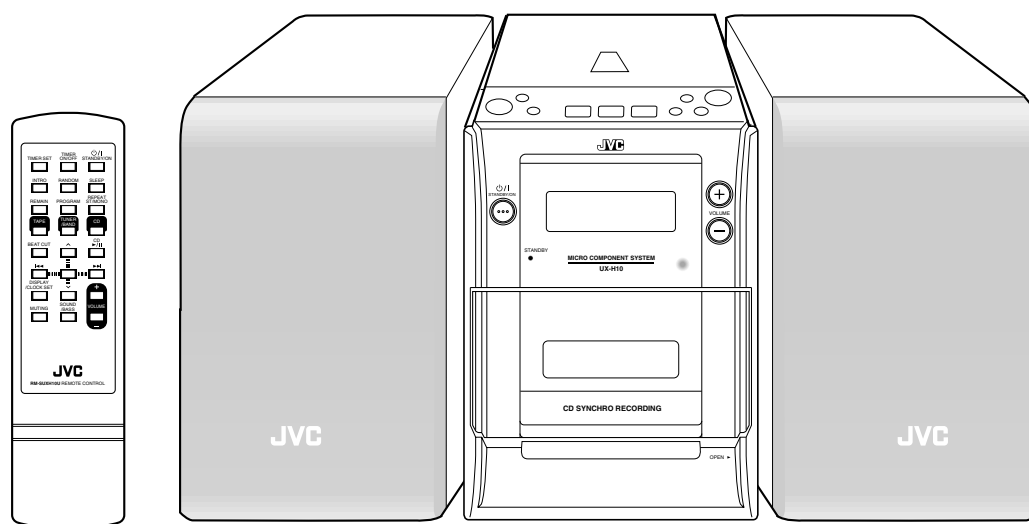

COMPACT
disc
DIGITAL AUDIO

INSTRUCTIONS

使用说明书

LVT1092-007A
[US]

Warnings, Cautions and Others

警告，注意及其他须知事项

CAUTION—/I STANDBY/ON button !

Disconnect the mains plug to shut the power off completely (all lamps and indications go off). The /I STANDBY/ON button in any position does not disconnect the mains line.

- When the unit is on standby, the STANDBY lamp lights red.
- When the unit is turned on, the STANDBY lamp goes off.

The power can be remote controlled.

注意—/I STANDBY/ON 开关！

将主电源插头从插座上拔出以完全关闭电源（全部灯光和指示灯熄灭）。/I STANDBY/ON 开关处于任何状况也没有完全有完全切断主线。

- 当本机处于备用模式时，STANDBY 灯将亮起红色。
- 当本机被启动时，STANDBY 灯将熄灭。

电源开关可用遥控器控制。

CAUTION

To reduce the risk of electrical shocks, fire, etc.:

1. Do not remove screws, covers or cabinet.
2. Do not expose this appliance to rain or moisture.

注意

为了防止触电，火灾等危险：

1. 请勿擅自卸下螺丝钉，盖子或机壳。
2. 切勿让本机受雨淋或置于潮湿环境中。

CAUTION

- Do not block the ventilation openings or holes.
(If the ventilation openings or holes are blocked by a newspaper or cloth, etc., the heat may not be able to get out.)
- Do not place any naked flame sources, such as lighted candles, on the apparatus.
- When discarding batteries, environmental problems must be considered and local rules or laws governing the disposal of these batteries must be followed strictly.
- Do not expose this apparatus to rain, moisture, dripping or splashing and that no objects filled with liquids, such as vases, shall be placed on the apparatus.

注意

- 请勿堵塞通风口或通风孔。
(如果通风口或通风孔被报纸或布等堵塞，热量将无法散出。)
- 请勿在本设备上放置任何裸露的火源，如点燃的蜡烛。
- 处理废弃电池时，必须考虑环境问题，并严格遵守当地关于处理废弃电池的有关法律或规定。
- 切勿将本装置暴露于雨水所及、潮湿、滴水或易于溅起水花的地方，亦不要将任何装满液体的物件（如花瓶）放置在本装置上。

IMPORTANT FOR LASER PRODUCTS

镭射产品的重要说明

REPRODUCTION OF LABELS

标签内容说明

① CLASSIFICATION LABEL ON EXTERIOR SURFACE

② WARNING LABEL INSIDE THE UNIT

① 位于机表的分类说明文

② 位于机内的警告说明文

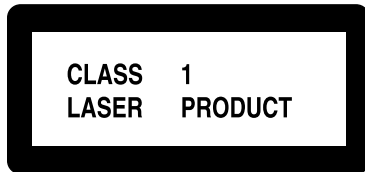

CAUTION: Invisible laser radiation when open and interlock failed or defeated. AVOID DIRECT EXPOSURE TO BEAM. (e)

ADVARSEL: Usynlig laserstråling ved åbning, når sikkerhedsafbrydere er ude af funktion. Undgå udsættelse for stråling (d)

WARNING: Osynlig laserstråling när denna del är öppnad och spärren är urkopplad. Beträkta ej strålen. (s)

VARO: Avattaessa ja suojalukitus ohitettaessa olet alttiina näkymättömälle lasersäteilylle. Älä katso säteeseen. (f)

1. CLASS 1 LASER PRODUCT
2. **CAUTION:** Invisible laser radiation when open and interlock failed or defeated. Avoid direct exposure to beam.
3. **CAUTION:** Do not open the top cover. There are no user serviceable parts inside the unit; leave all servicing to qualified service personnel.

1. 一级镭射产品
2. **注意：**当内部锁定装置失效或者损坏后，打开盖板可能会产生不见的镭射辐射。应避免受到光束直接照射。
3. **注意：**请勿打开顶盖板，本机内部没有用户可自行维修的部件；所有维修工作应由有资格的人员完成。

CAUTION: Proper Ventilation

To avoid risk of electric shock and fire, and to prevent damage, locate the apparatus as follows:

- 1 Front:
No obstructions and open spacing.
- 2 Sides/ Top/ Back:
No obstructions should be placed in the areas shown by the dimensions below.
- 3 Bottom:
Place on a level surface. Maintain an adequate air path for ventilation by placing on a stand with a height of 10 cm or more.

注意：正确通风

为避免发生触电和火警的危险，及防止本机受损，请将本机如下放置：

1. 前面：没有障碍物及地方开阔。
2. 侧面 / 顶面 / 背面：在图中所示范围中，不应放置任何障碍物。
3. 底部：放置在水平面上。放置在一个高 10 厘米或以上的台面上，以保持足够的通风道。

Front view

前面

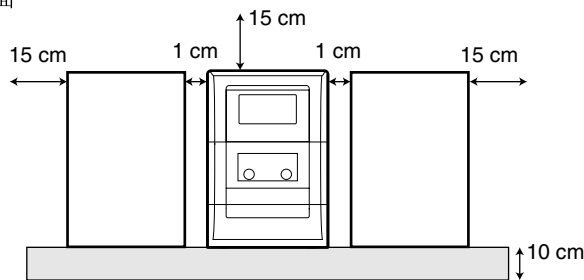

UX-H10

Side view

侧面

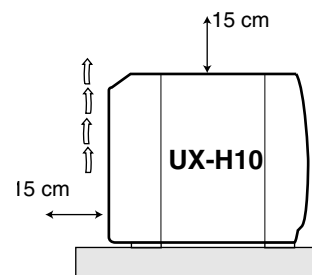

UX-H10

Introduction

We would like to thank you for purchasing one of our JVC products. Before operating this unit, read this manual carefully and thoroughly to obtain the best possible performance from your unit, and retain this manual for future reference.

About This Manual

This manual is organized as follows:

- **This manual mainly explains operations using the buttons on the remote control. You can use the buttons both on the remote control and on the unit for the same operations if they have the same or similar names (or marks), unless mentioned otherwise.**
- Basic and common information that is the same for many functions is grouped in one place, and is not repeated for each procedure. For instance, we do not repeat the information about turning on/off the unit, setting the volume, changing the sound effects, and others, which are explained in the section “Basic and Common Operations” on pages 8 and 9.
- The following symbols are used in this manual:



Gives you warning and caution to prevent damage or risk of fire/electric shock. In addition, we put information here about conditions which will prevent getting the best possible performance from the unit.



Gives you information and hints you need to know.

Precautions

Installation

- Install in a place which is level, dry and neither too hot nor too cold—between 5°C and 35°C.
- Install the unit in a location with adequate ventilation to prevent internal heat buildup.
- Leave sufficient distance between the unit and the TV.
- Keep the speakers away from the TV to avoid interference with TV.



DO NOT install the unit in a location near heat sources, or in a place subject to direct sunlight, excessive dust or vibration.

Power sources

- When unplugging the unit from the wall outlet, always pull on the plug, not the AC power cord.



DO NOT handle the AC power cord with wet hands.

Moisture condensation

Moisture may condense on the lenses inside the unit in the following cases:

- After starting to heat the room.
- In a damp room.
- If the unit is brought directly from a cold to a warm place. Should this occur, the unit may malfunction. In this case, leave the unit turned on for a few hours until the moisture evaporates, unplug the AC power cord, then plug it in again.

Others

- Should any metallic object or liquid fall into the unit, unplug the AC power cord and consult your dealer before operating any further.
- If you are not going to operate the unit for an extended period of time, unplug the AC power cord from the wall outlet.



DO NOT disassemble the unit since there are no user serviceable parts inside.

If anything goes wrong, unplug the AC power cord and consult your dealer.

Location of the Buttons and Controls	3
Main Unit	3
Remote Control	5
Getting Started	6
Unpacking	6
Putting the Batteries into the Remote Control	6
Connections	6
Adjusting the Voltage Selector	7
Basic and Common Operations	8
Setting the Clock	8
Turning On the Power	8
Selecting the Source	9
Adjusting the Volume	9
Selecting the Sound Modes	9
Reinforcing the Bass Sound	9
Listening to FM and AM Broadcasts	10
Setting the Tuner Interval Spacing	10
Tuning in to a Station	10
Presetting Stations	11
Tuning in to a Preset Station	11
Playing Back Discs	12
Playing Back the Entire Disc—Normal Play	12
Basic Disc Operations	13
Programming the Track Playing Order	
—Program Play	13
Playing at Random—Random Play	14
Repeating Tracks—Repeat Play	14
Playing only Introductions—Intro Play	14
Displaying the Remaining Time during Playback	14
Playing Back Tapes	15
Playing Back a Tape	15
Recording	16
Recording from the Radio	16
Recording Discs	
—Disc Synchronized Recording	17
Using the Timers	18
Using the Daily Timer	18
Using the Sleep Timer	19
Maintenance	20
Troubleshooting	21
Specifications	22

Location of the Buttons and Controls

Become familiar with the buttons and controls on your unit.

Main Unit

Top view

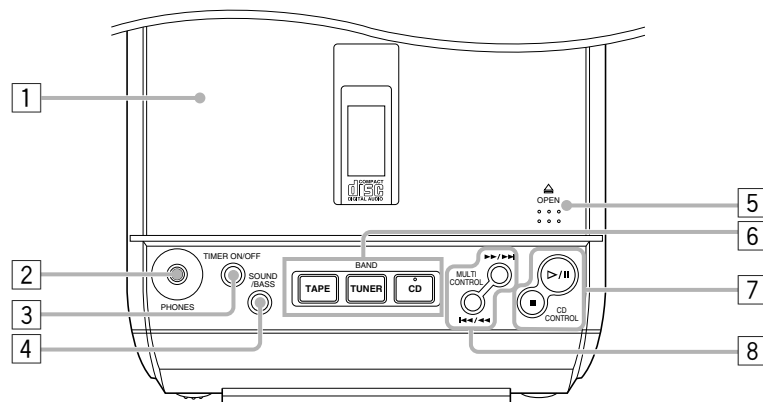

Front view

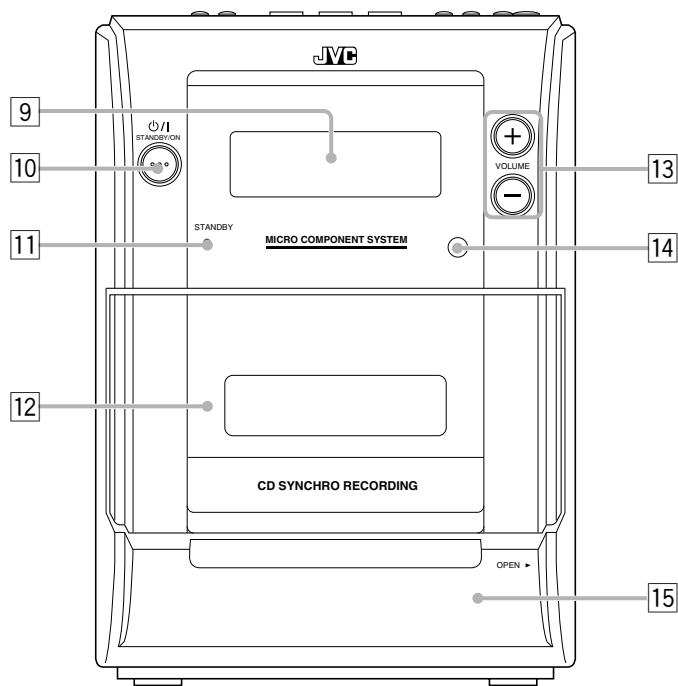

Inside the front cover

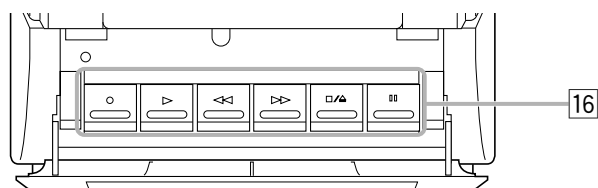

Display window on the front panel

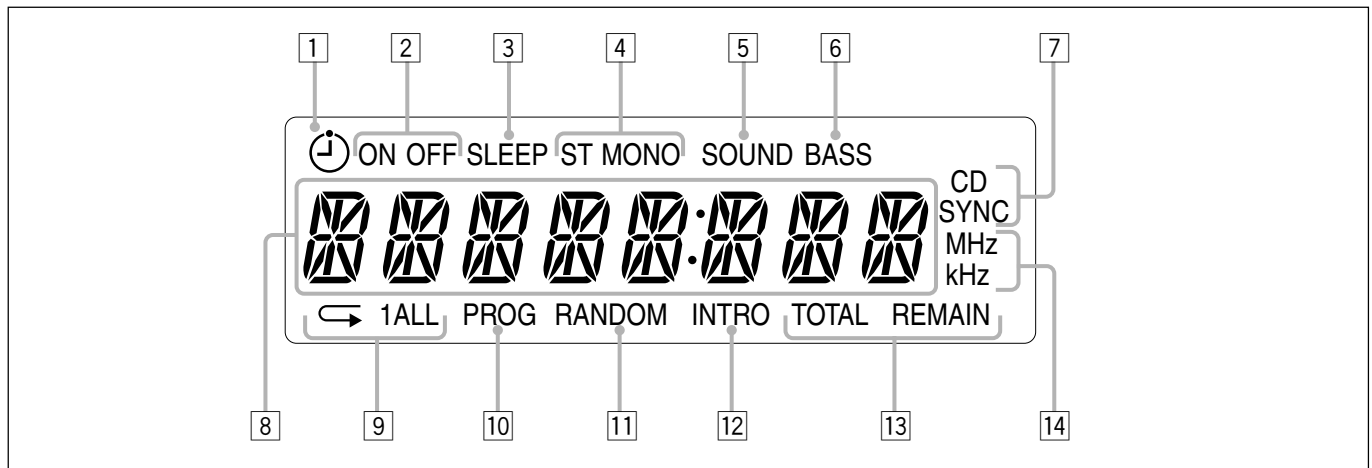

See pages in parentheses for details.

Main unit

- 1 Disc cover (12)
- 2 PHONES jack (9)
- 3 TIMER ON/OFF button (8, 19)
- 4 SOUND/BASS button (9)
- 5 ▲ OPEN (disc cover open) (12, 13)
- 6 Source buttons
 - TAPE, TUNER/BAND, CD*Pressing one of these buttons also turns on the unit.*
- 7 CD CONTROL buttons (8, 11, 12, 13)
 - ▷/||, ■
- 8 MULTI CONTROL buttons
 - ▶▶/▶▶, ◀◀/◀◀
- 9 Display window
- 10 ⏻/⏻ STANDBY/ON button (8, 11, 19)
- 11 STANDBY lamp (8)
- 12 Cassette holder (15)
- 13 VOLUME + / - buttons (9)
- 14 Remote sensor (5)
- 15 Front cover (15)
- 16 Tape operation buttons (15 – 17)
 - ○ (recording), ▷ (play), ◀◀ (fast backward), ▶▶ (fast forward), ◻/⏻ (stop/cassette holder open), ◻◻ (pause)

Display window

- 1 ⏻ (timer) indicator
- 2 ON/OFF (timer on-time/off-time) indicators
- 3 SLEEP indicator
- 4 FM mode indicators
 - ST (stereo), MONO
- 5 SOUND indicator
- 6 BASS indicator
- 7 CD SYNC (syncro) indicator
- 8 Main display
 - Shows the source name and other information.
- 9 Repeat indicators
 - ↶, 1, ↷
- 10 PROG (program) indicator
- 11 RANDOM indicator
- 12 INTRO indicator
- 13 Time indicators
 - TOTAL, REMAIN
- 14 Frequency indicators
 - MHz, kHz

To open the front cover

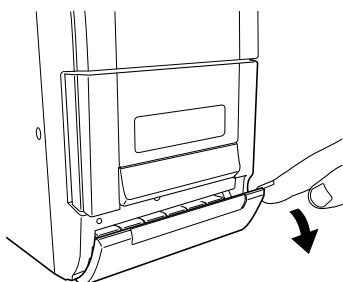

Remote Control

See pages in parentheses for details.

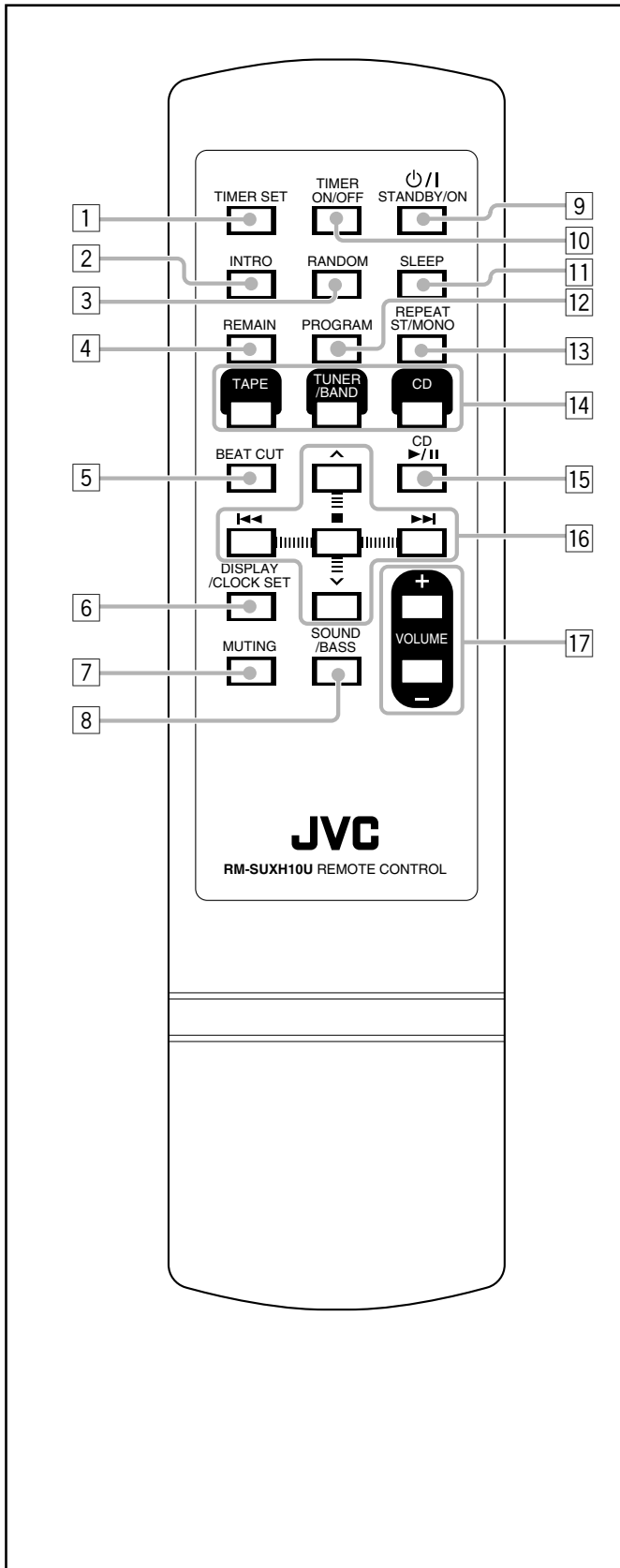

- 1 TIMER SET button (18, 19)
- 2 INTRO button (14)
- 3 RANDOM button (14)
- 4 REMAIN button (14)
- 5 BEAT CUT button (10, 16)
- 6 DISPLAY/CLOCK SET button (8)
- 7 MUTING button (9)
- 8 SOUND/BASS button (9)
- 9 O/I STANDBY/ON button (8, 19)
- 10 TIMER ON/OFF button (19)
- 11 SLEEP button (19)
- 12 PROGRAM button (8, 11, 13, 18, 19)
- 13 REPEAT ST/MONO button (10, 14)
- 14 Source buttons
 - TAPE, TUNER/BAND, CD
 Pressing one of these buttons also turns on the unit.
- 15 CD $\blacktriangleright/\parallel$ button (12, 13)
- 16 Multi control buttons
 - \wedge, \vee
 - $\blacktriangleleft, \blacksquare, \blacktriangleright$
- 17 VOLUME + / - buttons (9)

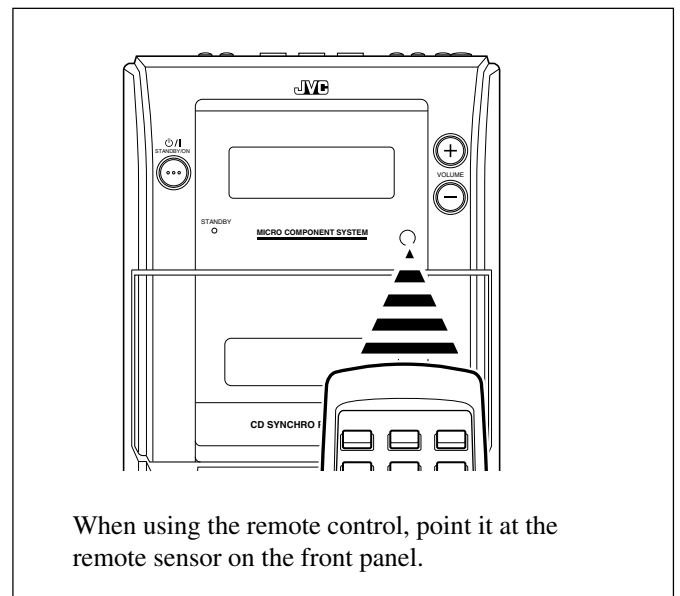

Unpacking

After unpacking, check to be sure that you have all the following items.

The number in parentheses indicates the quantity of each piece supplied.

- AM loop antenna (1)
- Remote control (1)
- Batteries (2)
- AC plug adaptor (1)

If any item is missing, consult your dealer immediately.

Putting the Batteries into the Remote Control

Insert the batteries—R03(UM-4)/AAA(24F)—into the remote control by matching the polarity (+ and -) on the batteries with the + and - marking on the battery compartment.

When the remote control can no longer operate the unit, replace both batteries at the same time.

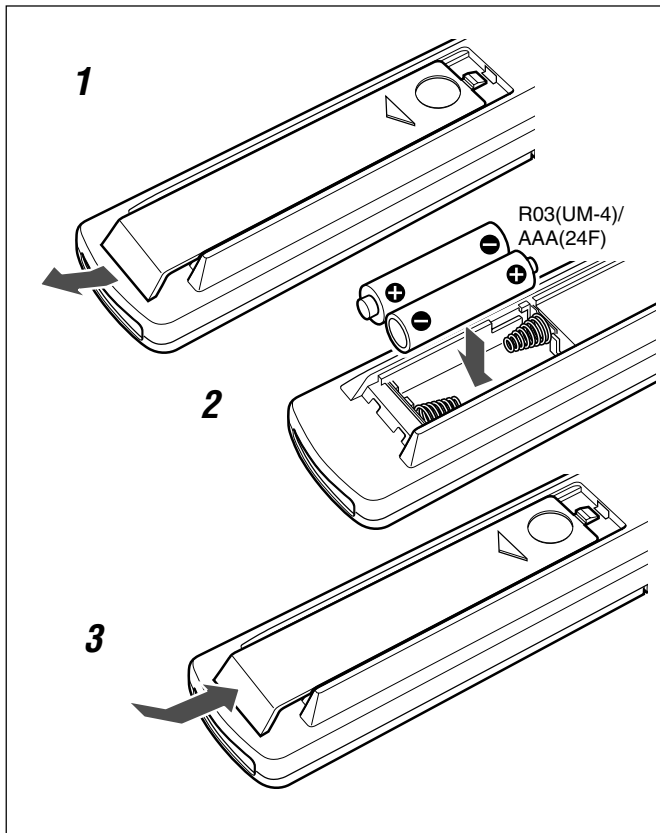

- DO NOT use an old battery together with a new one.
- DO NOT use different types of batteries together.
- DO NOT expose batteries to heat or flame.
- DO NOT leave the batteries in the battery compartment when you are not going to use the remote control for an extended period of time. Otherwise, the remote control will be damaged from battery leakage.

Connections

To connect speakers

You can connect the speakers using the speaker cords.

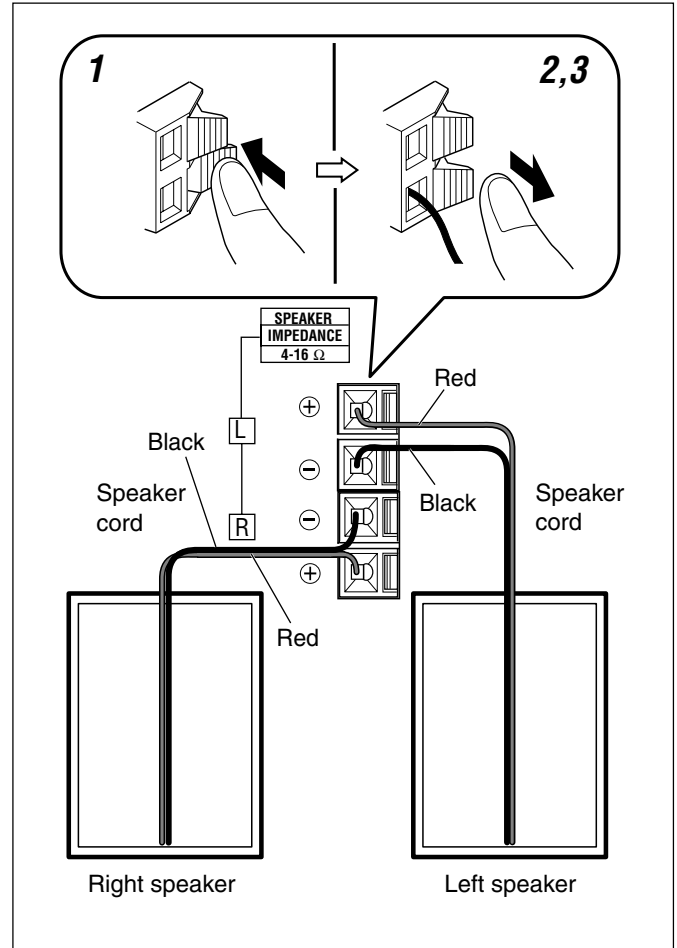

1 Hold the clamp of the speaker terminal.

2 Insert the end of the speaker cord into the terminal.

Match the polarity of the speaker terminals: red (⊕) to red (⊕) and black (⊖) to black (⊖).

3 Release your finger from the clamp.

IMPORTANT:

- Use only speakers with the same speaker impedance as indicated by the speaker terminals on the rear of the unit.
- DO NOT connect more than one speaker to one speaker terminal.

To connect AM and FM antennas

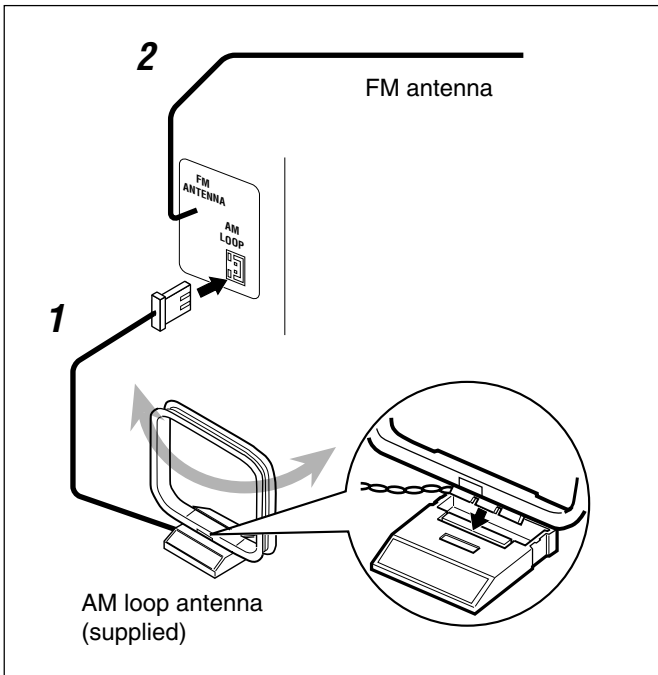

1 Connect the supplied AM loop antenna to the AM LOOP terminal.

Place the antenna away from the unit and adjust its position for the best reception.

2 Adjust the position for the FM antenna for the best reception.



For better reception of both FM and AM

- Make sure the antenna conductors do not touch any other terminals or connecting cords.
- Keep the antennas away from metallic parts of the unit, connecting cords, and the AC power cord.

Adjusting the Voltage Selector

Before plugging in the unit, set the correct voltage for your area with the voltage selector on the bottom of the unit.

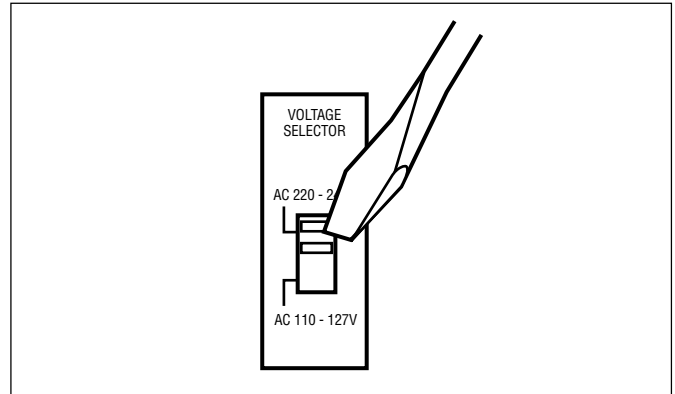

Use a screwdriver to move the voltage selector so the voltage number is the same as the voltage where you are plugging in the unit. (See the back cover page.)



- DO NOT plug in before setting the voltage selector on the bottom of the unit and all connection procedures are complete.
- DO NOT drag the unit when moving it. Dragging may possibly change the voltage selector setting accidentally.

NOW you are ready to plug in the unit.

- If the wall outlet does not match the AC plug, use the supplied AC plug adaptor.

IMPORTANT:

Be sure to check that all connections have been made before plugging in the power cord.

Setting the Clock

Before operating the unit any further, first set the unit's clock. When you plug in the power cord, "0:00" starts flashing on the display.

You can set the clock when the unit is either turned on or in standby mode.

- In the following procedure, the clock is set to 24-hour system.

On the remote control ONLY:

1 When the unit is in standby mode, press and hold PROGRAM until the hour indication starts flashing.



- When the unit is on, press DISPLAY/CLOCK SET to enter clock mode, then press and hold PROGRAM.

2 Press ◀◀ or ▶▶ to adjust the hour, then press PROGRAM.

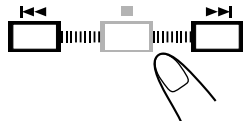

- When you press and hold ◀◀ or ▶▶, the hour indication changes continuously.

The minute indication start flashing.

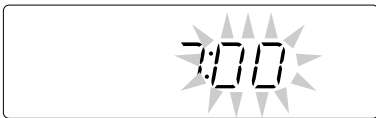

3 Press ◀◀ or ▶▶ to adjust the minute, then press PROGRAM.

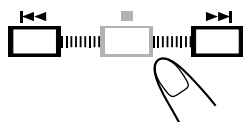

- When you press and hold ◀◀ or ▶▶, the minute indication changes continuously.

The built-in clock starts.

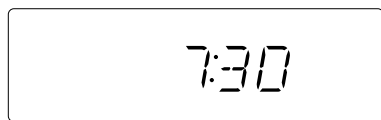

- **When you unplug the AC power cord or if a power failure occurs**
The clock is reset to "0:00" right away. If this happens, set the clock again.
- **The clock may gain or lose 1 to 2 minutes per month**
If this happens, reset the clock.

To select 12-hour or 24-hour clock system

You can select 12-hour or 24-hour for the clock system only while the unit is in standby mode.

On the unit ONLY:

To change the clock setting, press TIMER ON/OFF while holding down ■.

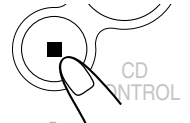

- Each time you press TIMER ON/OFF, the clock change alternates between 12-hour and 24-hour system.

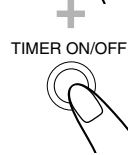

To show the clock when the unit is turned on

On the remote control ONLY:

Press DISPLAY/CLOCK SET.

- Each time you press the button, the display changes the clock indication and the normal indication alternately.

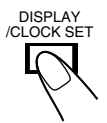

To change the clock

Repeat steps 1 to 3 of the procedure "Setting the Clock."

Turning On the Power

To turn on the unit, press ◻/I STANDBY/ON. The STANDBY lamp on the unit goes off.



- When you press the source button—TAPE, TUNER/BAND and CD, the unit automatically turns on.

To turn off the unit (standby), press ◻/I STANDBY/ON again. The STANDBY lamp on the unit lights red.

- "0:00" flashes on the display until you set the built-in clock. After setting the clock, the clock time will appear on the display while the unit is on standby.
- A little power is always consumed even while the unit is in standby mode.

To switch off the power supply completely, unplug the AC power cord from the AC outlet.



- **When you unplug the AC power cord or if a power failure occurs**
The clock is reset to "0:00" right away. If this happens, set the clock again.

Selecting the Source

To select the source, press TAPE, TUNER/BAND, or CD.

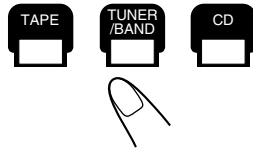

- When you select TAPE or CD as the source, playback does not start automatically.

To operate the tuner (FM or AM), see pages 10 and 11.

To operate the CD player, see pages 12 – 14.

To operate the tape deck, see page 15.

To record on a tape, see pages 16 and 17.

Adjusting the Volume

You can adjust the volume level only while the unit is turned on. The volume level can be adjusted between “VOL MIN,” “VOL 1” – “VOL 39,” and “VOL MAX.”

- The volume level has no effect on recording.

To increase the volume, press VOLUME +.

To decrease the volume, press VOLUME –.

- When you press and hold either button, you can change the volume level continuously.

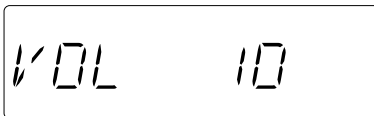

To turn off the sound temporarily

On the remote control ONLY:

Press **MUTING**.

The volume level turn down and “MUTING” starts flashing on the display.



To restore the sound, press **MUTING** again.

- Adjusting the volume level also cancels the muting.



For private listening

Connect a pair of headphones to the PHONES jack. No sound comes out of the speakers. Be sure to turn down the volume before connecting or putting on the headphones.



DO NOT turn off (standby) the unit with the volume set to an extremely high level; Otherwise, the sudden blast of sound can damage your hearing, speakers and/or headphones when you turn on the unit or start playing any source. REMEMBER you cannot adjust the volume level while the unit is in standby mode.

Selecting the Sound Modes

You can select one of the 4 sound modes.

- This function also affects the sound from headphones.
- This function only affects the playback sound, and does not affect your recording.

To select the sound modes, press **SOUND/BASS** repeatedly.

- Each time you press the button, the sound mode changes as follows:



POP: More presence in the vocals and midrange.

CLASSIC: Enriched sound with fine treble and ample bass.

ROCK: Powerful sound emphasizing treble and bass.

JAZZ: Accented lower frequencies for jazz-type music.

FLAT: Equalizer effect is canceled.

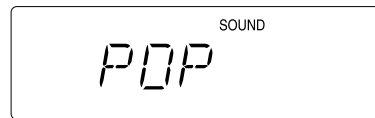

When the sound mode is activated, the **SOUND** indicator lights up on the display.

Reinforcing the Bass Sound

The richness and fullness of the bass sound is clearly maintained regardless of how low you set the volume—Hyper Bass Sound.

- This function also affects the sound from headphones.
- This function only affects the playback sound, and does not affect your recording.

To get the effect, press and hold **SOUND/BASS** until “HBS ON” appears and the **BASS** indicator lights up on the display.

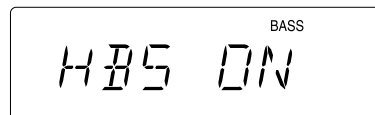

- Each time you press and hold the button, the effect alternates (“HBS ON”) and off (“HBS OFF”).

To cancel the effect, press and hold **SOUND/BASS** again until “HBS OFF” appears and the **BASS** indicator goes off.

Listening to FM and AM Broadcasts

Setting the Tuner Interval Spacing

You can select 10 kHz or 9 kHz apart for the AM tuner interval spacing and 100 kHz or 50 kHz apart for the FM tuner interval spacing.

- You need to do this setting separately for each band.

On the unit ONLY:

1 Press TUNER/BAND to select either “FM” or “AM.”

The unit automatically turns on and tunes in to the previously received station—either FM or AM.

- Each time you press the button, the band alternates between FM and AM.



2 Press \odot/I STANDBY/ON while holding down \blacksquare .

- Each time you press \odot/I STANDBY/ON, the interval spacing alternates as follows:

While selecting the AM tuner

10K (10 kHz) \leftrightarrow 9K (9 kHz)

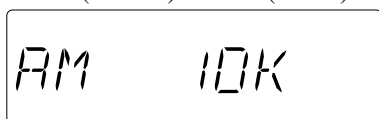

While selecting the FM tuner

100K (100 kHz) \leftrightarrow 50K (50 kHz)

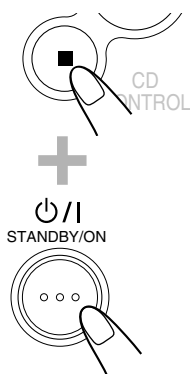

When you change the setting

The preset stations are erased. You will need to preset the stations again. (See page 11.)

Tuning in to a Station

1 Press TUNER/BAND to select either “FM” or “AM.”

The unit automatically turns on and tunes in to the previously received station—either FM or AM.

- Each time you press the button, the band alternates between FM and AM.

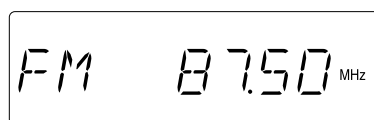

2 Press and hold $\blacktriangleright\blacktriangleright$ or $\blacktriangleleft\blacktriangleleft$ (or $\blacktriangleright/\blacktriangleright$ or $\blacktriangleleft/\blacktriangleleft$ on the unit) for more than 1 second.

- $\blacktriangleright\blacktriangleright$ ($\blacktriangleright/\blacktriangleright$): Increases the frequencies.
- $\blacktriangleleft\blacktriangleleft$ ($\blacktriangleleft/\blacktriangleleft$): Decreases the frequencies.

The unit starts searching for stations and stops when a station of sufficient signal strength is tuned in.

- If an FM program is broadcast in stereo, the ST (stereo) indicator lights up on the display (only when the reception is good).

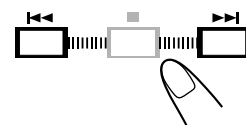

To stop during searching, press $\blacktriangleright\blacktriangleright$ or $\blacktriangleleft\blacktriangleleft$ (or $\blacktriangleright/\blacktriangleright$ or $\blacktriangleleft/\blacktriangleleft$ on the unit).



When you repeatedly press $\blacktriangleright\blacktriangleright$ or $\blacktriangleleft\blacktriangleleft$ (or $\blacktriangleright/\blacktriangleright$ or $\blacktriangleleft/\blacktriangleleft$ on the unit)

The frequency changes step by step.

To change the FM reception mode

On the remote control ONLY:

When an FM stereo broadcast is hard to receive or noisy, press REPEAT ST/MONO so that the MONO indicator lights up on the display. Reception will improve.



To restore the stereo effect, press REPEAT ST/MONO again so that the MONO indicator goes off. In stereo mode, you can hear stereo sound when a stereo program is broadcast.

To reduce the beat—Beat Cut

On the remote control ONLY:

If the beats are heard while listening a broadcast, press BEAT CUT.



Presetting Stations

You can preset 20 FM and 20 AM stations manually.

In some cases, test frequencies have been already stored for the tuner since the factory examined the tuner preset function before shipment. This is not a malfunction. You can preset the stations you want into memory by following the presetting method.

- There is a time limit in doing the following steps. If the setting is canceled before you finish, start again from step 2.

On the remote control ONLY:

1 Tune in to the station you want to preset.

- See “Tuning in to a Station” on page 10.

2 Press PROGRAM.

The PROG (program) indicator and “00” start flashing on the display.



3 Press ^ or v to select a preset number.

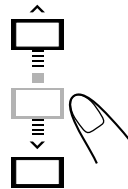
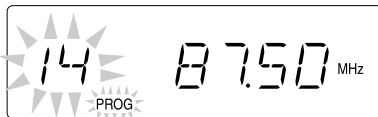

4 Press PROGRAM again.

The PROG indicator and the selected preset number stop flashing.



5 To preset more stations, repeat steps 1 to 4 above, allocating a different preset number to each station.

- Storing a new station on an already assigned number erases the previously stored one.



When you unplug the AC power cord or if a power failure occurs

The preset stations will remain in the unit.

Tuning in to a Preset Station

On the remote control ONLY:

1 Press TUNER/BAND to select either “FM” or “AM.”

The unit automatically turns on and tunes in to the previously received station—either FM or AM.

- Each time you press the button, the band alternates between FM and AM.



2 Press ^ or v to select a preset number.

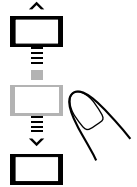

This unit has been designed to play back the following discs—CD, CD-R, and CD-RW.

When playing a CD-R or CD-RW

User-edited CD-Rs (CD-Recordable) and CD-RWs (CD-ReWritable) can be played only if they are already “finalized.”

- Usually you can play back your original CD-Rs or CD-RWs recorded in music CD format. However, sometimes they may not play depending on their characteristics or recording conditions.
- Before playing CD-Rs or CD-RWs, read their instructions or cautions carefully.
- Some CD-Rs or CD-RWs may not play on this unit because of their disc characteristics, damage or stain on them, or if the player’s lens is dirty.
- CD-RWs may require a longer readout time. This is because the reflectance of CD-RWs is lower than for regular discs.

General notes

In general, you will have the best performance by keeping your discs and the mechanism clean.

- Store discs in their cases, and keep them in cabinets or on shelves.
- Keep the unit’s disc trays closed when not in use.

Continued use of irregular shape discs (heart-shape, octagonal, etc.) can damage the unit.



Playing Back the Entire Disc—Normal Play

1 Press **OPEN** on the unit.

The disc cover opens.

- You can insert a disc while listening to another source.

2 Place a disc correctly with its label side up.

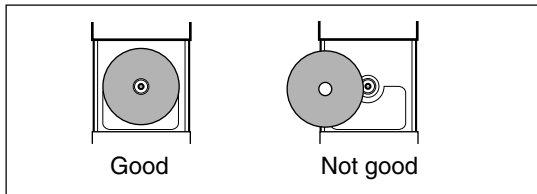

3 Close the disc cover gently.

4 Press **CD**.

The unit automatically turns on and the source changes to the CD player. After loading the disc, total track number and total playing time appear on the display.

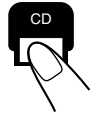

Total track number Total playing time

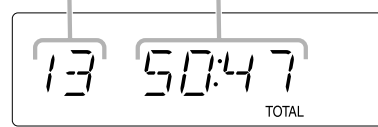

5 Press **CD ▶/||**.

The first track of the disc starts playing.



Current track number

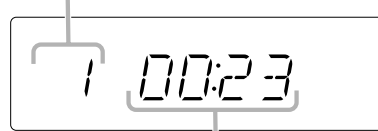

Elapsed playing time

- The disc automatically stops when the last track has finished playing.

To stop playing, press **■**.

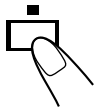

To remove the disc, press **OPEN** on the unit.



- If the disc cannot be read correctly (because it is scratched, for example) or an unreadable CD-R or CD-RW is inserted Playback will not start.
- If no disc is inserted “NO DISC” appears on the display.

 DO NOT try to open the disc cover by hand as it will be damaged.

Basic Disc Operations

While playing a disc, you can do the following operations.

To stop playing for a moment

During play, press CD ►/||.

While pausing, the elapsed playing time flashes on the display.



To resume playing, press CD ►/|| again.

To go to another track

Before or during play, press ►► or ◀◀ repeatedly.

- ►►: Skips to the beginning of the next or succeeding tracks.
- ◀◀: Goes back to the beginning of the current or previous tracks.

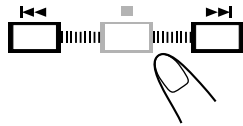

To locate a particular point in a track

During play, press and hold ►► or ◀◀.

- ►►: Fast-forwards the tracks.
- ◀◀: Fast-reverses the tracks.

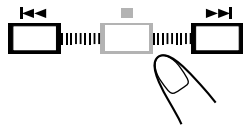

Programming the Track Playing Order —Program Play

You can arrange the order in which tracks play before you start playing. You can program up to 60 tracks.

On the remote control ONLY:

1 Place a disc.

- If the current source is not the CD player, press CD.

2 Press PROGRAM.

The PROG (program) indicator starts flashing on the display.

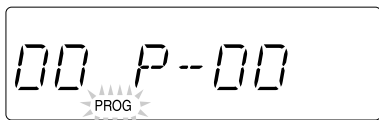

- If a program has been stored in memory, the program is called up.

3 Press ►► or ◀◀ to select the track number, then press PROGRAM.

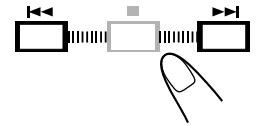

Track number Program step number

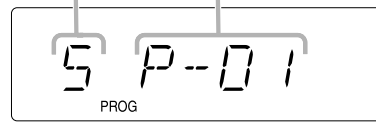

4 Repeat step 3 to program other tracks you want.

5 Press CD ►/||.

The tracks are played in the order you have programmed.



If you try to program a 61st track "FULL" will appear on the display.

To stop playing, press ■.

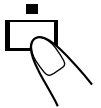

To check the program contents

Press PROGRAM repeatedly in stop mode. The program number and track number are displayed in succession.



To modify the program

Press PROGRAM repeatedly in stop mode to select the number which you want to change the track, then repeat step 3 above.



To clear the program

Press ■ in stop mode.

The PROG indicator disappears from the display.

- Pressing ▲ OPEN to open the disc cover will also erase the programmed tracks.

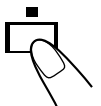

Playing at Random—Random Play

You can play the tracks at random.

On the remote control ONLY:

Press **RANDOM** before or during playing.

The **RANDOM** indicator lights up on the display.

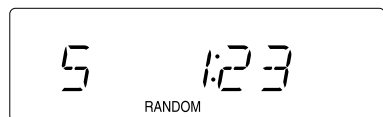

To exit from **Random Play**, press **RANDOM** again. The **RANDOM** indicator goes off.



- It is not possible to activate the random play function during Program Play.

Repeating Tracks—Repeat Play

You can have all the tracks, the program or individual track currently playing, repeat as many times as you like.

On the remote control ONLY:

Press **REPEAT ST/MONO** repeatedly before or during playing.

- Each time you press the button, Repeat Play changes as follows, and the following repeat indicator lights up on the display:

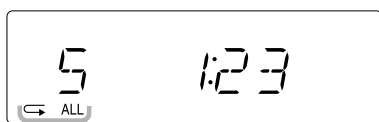
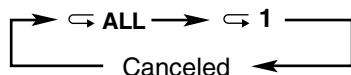

Repeat indicators

- ↶ **ALL**: In Normal Play, repeats all the tracks. In Program Play, repeats all the tracks in the program. In Random Play, repeats all the tracks in random order.
- ↶ **1**: Repeats one track.

To cancel **Repeat Play**, press **REPEAT ST/MONO** repeatedly until the repeat indicator goes off.



- Repeat Play remains in effect even when you select another play mode (Normal, Program, Random, or Intro Play).
- In Random Play, ↶ **1** cannot be selected. If ↶ **1** has been selected when you press **RANDOM**, it is canceled.
- If you select ↶ **1** in Random Play, Random Play is canceled.

Playing only Introductions—Intro Play

You can play only the introductions of the tracks.

On the remote control ONLY:

Press **INTRO**.

The **INTRO** indicator lights up and the first 10-second portion of each track is played back in order.



To cancel **Intro Play**, press **INTRO** again. The **INTRO** indicator goes off.

- Intro Play remains in effect even when you select another play mode (Program or Random Play).

Displaying the Remaining Time during Playback

You can display the remaining time of the current track/disc and the elapsed time of the current track/disc during playing.

On the remote control ONLY:

Press **REMAIN** repeatedly.

- Each time you press the button, the display changes as follows, and the following indicators light up on the display:

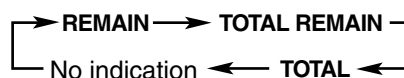

- REMAIN**: Shows the remaining time of the current track.
- TOTAL REMAIN**: Shows the remaining time and track number of the disc.
- TOTAL**: Shows the elapsed time of the disc.
- No indication**: Shows the elapsed time of the current track.

Playing Back Tapes

For Tape operations, use buttons inside the front cover on the unit.

Playing Back a Tape

You can play back type I tapes only.

On the unit ONLY:

1 Open the front cover.

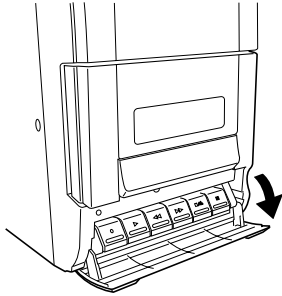

2 Press □/△ (stop/cassette holder open).

The cassette holder opens.

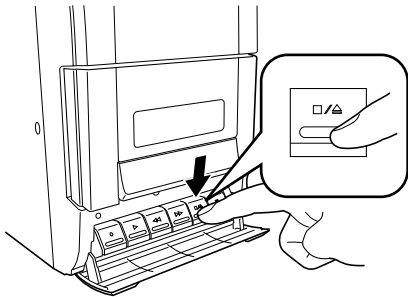

3 Put a cassette in with the exposed part of the tape down.

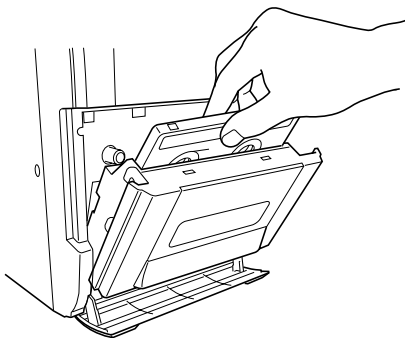

4 Close the cassette holder gently.

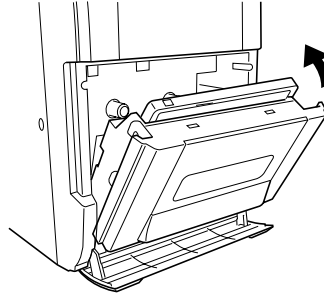

5 Press TAPE.

The unit automatically turns on and the source changes to the tape deck.

- You can select to the tape by pressing TAPE on the remote control.



6 Press ▷ (play).

The tape starts playing.

- When the end of the tape is reached, playing stops.

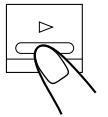

To stop playing, press □/△.

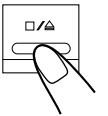

To stop playing for a moment, press || (pause).
To resume playing, press || again.

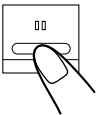

To fast forward or rewind the tape, press ▷▷ or ◀◀.

- The tape stops at the end of the fast forwarding or rewinding. To release the locked button, press □/△.

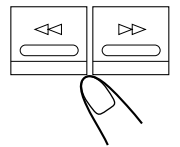

To remove the cassette, press □/△ while playback is stopped.

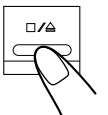

- DO NOT turn off the unit while playing back or recording a tape. The cassette deck or tapes may be damaged.
- The use of C-120 or longer tape is not recommended, since characteristic deterioration may occur and this tape easily jams in the pinch rollers and the capstans.
- This unit is not compatible with type II and type IV tapes.

IMPORTANT:

- It may be unlawful to record or play back copyrighted material without the consent of the copyright owner.
- The recording level is automatically set correctly, so it is not affected by the other sound settings. Thus, during recording you can adjust the sound you are actually listening to without affecting the recording level.
- If recordings you have made have excessive noise or static, the unit may be too close to a TV. Increase the distance between the TV and the unit.
- You can only use type I tape for recording.



- DO NOT turn off the unit while playing back or recording a tape. The cassette deck or tapes may be damaged.
- DO NOT use type II and type IV tapes since the unit is not compatible with such tapes.
- The use of C-120 or longer tape is not recommended, since characteristic deterioration may occur and this tape easily jams in the pinch rollers and the capstans.



At the start and end of cassette tapes

There is leader tape which cannot be recorded onto. Thus, when recording from discs, FM/AM broadcasts, or external equipment, wind the leader tape first to ensure that the recording will be made without losing any music.

To protect your recordings

Cassettes have two small tabs on the back to protect against unexpected erasure or re-recording.

To protect your recording, remove these tabs.

To re-record on a protected tape, cover the holes with adhesive tape.

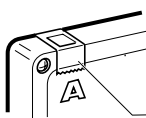

Adhesive tape

Recording from the Radio

On the unit ONLY:

1 Put a recordable cassette in with the exposed part of the tape down.

- See also page 15.

2 Close the cassette holder gently.

3 Press TUNER/BAND to select either “FM” or “AM.”

- When recording from discs, see “Recording Discs—Disc Synchronized Recording” on page 17.

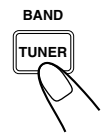

4 Tune in to the station you want to record.

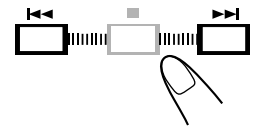

5 Press ○ (recording).

- ○ and ▷ lock down, and the recording starts.

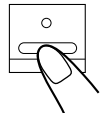

You cannot press ○ in the following cases:

- If no cassette is inserted.
- If a protected tape is inserted.

To stop recording for a moment, press ||| (pause).

To resume recording, press ||| again.

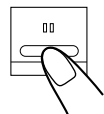

To stop recording, press □/△.

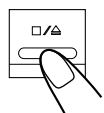

To remove the cassette, press □/△ while recording is stopped.



To record an AM station—Beat Cut

On the remote control ONLY:

While recording an AM broadcast, beats may be heard (which are never heard when listening to the broadcast without recording it).

If this occurs, press BEAT CUT repeatedly, while recording, until the beats are reduced.

- Each time you press the button, the display changes alternates “BEAT 01” and “BEAT 02.”



Recording Discs

—Disc Synchronized Recording

You can start disc play and recording at the same time.

On the unit ONLY:

1 Put a recordable cassette in with the exposed part of the tape down.

- See also page 15.

2 Close the cassette holder gently.

3 Press CD select the CD player as the source.

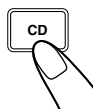

4 Press \circ (recording).

The CD SYNC indicator appears on the display and the CD starts playback automatically and the recording starts.

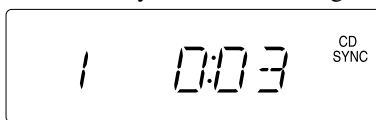
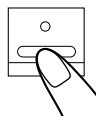

- When the end of the tape is reached, recording stops and the CD player is paused.
- If you press \circ while playing back the CD, the CD player return to the beginning of that track and the track is recorded on the tape.



You cannot press \circ in the following cases:

- If no cassette is inserted.
- If a protected tape is inserted.

To stop recording for a moment, press \square .

The recording is paused, but the CD playback does not stop.

To resume recording, press \square again.

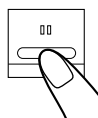

To stop recording, press \square/\triangle .

The recording stops and the CD playback is paused.



To remove the cassette, press \square/\triangle while recording is stopped.

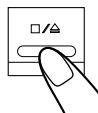

Daily Timer and Sleep Timer are available.

- Before using these timers, make sure the built-in clock is set correctly (see page 8).

Using the Daily Timer

You can set the Daily Timer when the unit is either turned on or in standby mode.

How the Daily Timer actually works

When the on-time comes, the unit automatically turns on and then the off-time comes, the unit automatically turns off (standby).

- Once the timer has been set, it will be activated at the same time everyday until the timer is turned off and the timer setting remains in memory until you change it.

Before you start...

When using "TUNER" as the source to play, make sure to select the desired station before turning off the power.

- In the following procedure, the clock is set to 24-hour system.
- There is a time limit in doing the following steps. If the setting is canceled before you finish, start again from step 1.

On the remote control ONLY:

1 Press TIMER SET.



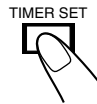

The  (timer) and the ON (on-time) indicators flash and the on-time setting appears on the display.

If you does not need to change the on-time setting, go to step 3.



2 Press PROGRAM to set the on-time you want the unit to turn on.

The hour indication starts flashing on the display.

- 1) Press  or  to set the hour, then press PROGRAM.
- 2) Press  or  to set the minute, then press PROGRAM.

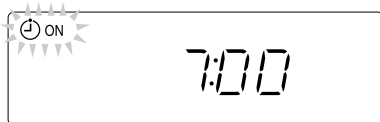
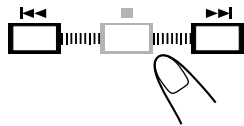

3 Press TIMER SET.

The  (timer) and the OFF (off-time) indicators flash and the off-time setting appears on the display.



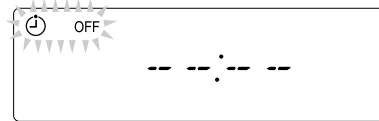

If you does not need to change the off-time setting, go to step 5.

- If you change the on-time setting, the off-time setting changes to "--:--". You need to set the off-time setting.



4 Press PROGRAM to set the off-time you want the unit to turn off.

The hour indication starts flashing on the display.

- 1) Press  or  to set the hour, then press PROGRAM.
- 2) Press  or  to set the minute, then press PROGRAM.

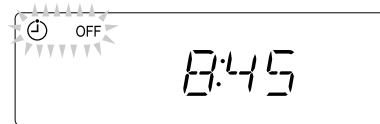
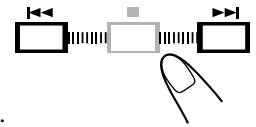

5 Press TIMER SET.

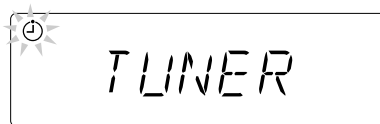

The  (timer) indicator flashes and the source name appears on the display.

If you does not need to change the source, go to step 7.



6 Press PROGRAM to select the source to play.

The source name starts flashing on the display.

- Press  or  to select "CD" or "TUNER," then press PROGRAM.

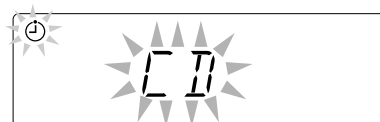
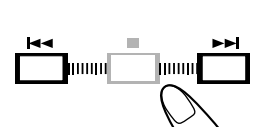

7 Press **TIMER SET**.

The display changes normal indication and exit the timer setting mode.



8 Press **TIMER ON/OFF** to activate the daily timer mode.

Each time you press the button, the Daily Timer alternates on and off.

While activating the Daily Timer, the Ⓢ (timer) indicator lights up on the display.

- You can activate the Daily Timer by pressing **TIMER ON/OFF** on the unit.

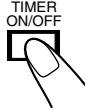

9 Press **⏻/| STANDBY/ON** to turn off the unit if the unit is on.

To deactivate the timer temporarily, press **TIMER ON/OFF** until the Ⓢ (timer) indicator goes off.



To activate and change the timer, repeat steps **1** to **8** on pages 18 and 19.

- To activate the timer again without changing the setting, press **TIMER ON/OFF** until the Ⓢ (timer) indicator lights up on the display.



If the unit is already turned on when the timer on-time comes

The timer does not work.



When you unplug the AC power cord or if a power failure occurs

The timer will be canceled. You need to set the clock first, then set the timer again.

Using the Sleep Timer

With the Sleep Timer, you can fall asleep to your favorite music or radio program.

- You can set the Sleep Timer only when the unit is turned on.

How the Sleep Timer actually works

The unit automatically turns off after the specified length of time passes.

On the remote control ONLY:

1 Press **SLEEP**.

The **SLEEP** indicator lights up on the display.



- Each time you press the button, the length of time changes as follows:

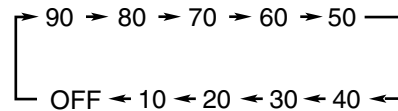

2 Wait for about 5 seconds after specifying the length of time.

To check the remaining time until shut-off time, press **SLEEP** once. The remaining time until shut-off time appears for about 5 seconds.

To change the shut-off time, press **SLEEP** repeatedly until the length of time you want appears.

To cancel the setting, press **SLEEP** repeatedly until "OFF" appears and the **SLEEP** indicator goes off on the display.

- Turning off the unit also cancels the Sleep Timer.



If you set the Sleep Timer after the Daily Timer starts playing the selected source

The Daily timer is canceled. The unit turns off when the Sleep Timer shut-off time comes.



If you set the Sleep Timer while playing back or recording a tape

Do not shut the unit off with the Sleep Timer while a tape is running. If the unit turns off while playing back or recording a tape, the cassette deck or tapes may be damaged.

Maintenance

To get the best performance of the unit, keep your discs, tapes and mechanism clean.

General Notes

In general, you will have the best performance by keeping your discs, tapes and the mechanism clean.

- Store discs and tapes in their cases, and keep them in cabinets or on shelves.

Cleaning the unit

• Stains on the unit

Should be wiped off with a soft cloth. If the unit is heavily stained, wipe it with a cloth soaked in water-diluted neutral detergent and wrung well, then wipe clean with a dry cloth.

- **Since the unit may deteriorate in quality, become damaged or have its paint peel off, be careful about the following:**
 - DO NOT wipe it with a rough cloth.
 - DO NOT wipe it too vigorously.
 - DO NOT wipe it with thinner or benzine.
 - DO NOT apply any volatile substance such as an insecticide to it.
 - DO NOT allow any rubber or plastic to remain in contact with it for a long time.

Handling discs



- Remove the disc from its case by holding it at the edge while pressing the center hole lightly.
- Do not touch the shiny surface of the disc, or bend the disc.
- Put the disc back in its case after use to prevent warping.

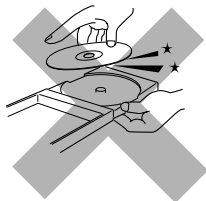

- Be careful not to scratch the surface of the disc when placing it back in its case.
- Avoid exposure to direct sunlight, temperature extremes, and moisture.



To clean the disc

Wipe the disc with a soft cloth in a straight line from center to edge.



DO NOT use any solvent—such as conventional record cleaner, spray, thinner, or benzine—to clean the disc.

Handling cassette tapes



- If the tape is loose in its cassette, take up the slack by inserting a pencil in one of the reels and rotating.
- If the tape is loose, it may get stretched, cut, or caught in the cassette.



- Be careful not to touch the tape surface.



- Avoid storing tapes in any of the following places:
 - In dusty places
 - In direct sunlight or heat
 - In moist areas
 - On a TV or speaker
 - Near a magnet

To keep the best recording and playback sound quality

You need to clean the heads.

- Clean the heads after every 10 hours of use with a wet-type head cleaning tape (available at electronic and audio shops).
When the head becomes dirty, the following symptoms will occur:
 - Sound quality is reduced.
 - Sound level decreases.
 - Sound drops out.
- Do not play dirty or dusty tapes.
- Do not touch the highly-polished head with any metallic or magnetic tools.

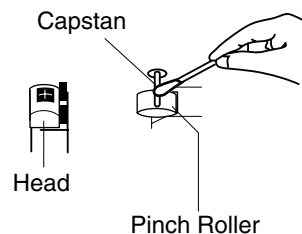

To demagnetize the head

Turn off the unit, and use a head demagnetizer (available at electronic and audio shops).

Troubleshooting

If you are having a problem with your unit, check this list for a possible solution before calling for service.

If you cannot solve the problem from the hints given here, or the unit has been physically damaged, call a qualified person, such as your dealer, for service.

Symptom	Possible Cause	Action
Power does not come on.	The power cord is not connected to an AC outlet.	Insert the plug into the socket.
No sound is heard.	<ul style="list-style-type: none"> • Connections are incorrect or loose. • A pair of headphones is connected. 	<ul style="list-style-type: none"> • Check all connections and make corrections. (See pages 6 and 7.) • Unplug the headphones from the PHONES jack.
Hard to listen to broadcasts because of noise.	<ul style="list-style-type: none"> • Antennas are disconnected. • The AM loop antenna is too close to the unit. • The FM antenna is not properly extended and positioned. 	<ul style="list-style-type: none"> • Reconnect the antenna correctly and securely. • Change the position and direction of the AM loop antenna. • Extend FM antenna and orient to the best reception position.
The disc does not play.	The disc is upside down.	Put the disc in with the label side up.
Impossible to record.	Small tabs on the back of the cassette are removed.	Cover the holes with adhesive tape.
Operations are disabled.	The built-in microprocessor has malfunctioned due to external electrical interference.	Unplug the AC power cord then plug it back in.
Unable to operate the unit by the remote control.	<ul style="list-style-type: none"> • The path between the remote control and the remote sensor on the unit is blocked. • The batteries are exhausted. • You are using the remote control too far from the unit. 	<ul style="list-style-type: none"> • Remove the obstruction. • Replace the batteries. (See page 6.) • Signals cannot reach the remote sensor. Move closer to the unit.

Amplifier Section—CA-UXH10

Output Power (IEC 268-3):

10 W (5 W + 5 W) at 4 Ω (10% THD)

Speakers/Impedance: 4 Ω – 16 Ω

Tuner

FM tuning range: 87.50 MHz—108.00 MHz

AM tuning range:

AM 10 kHz intervals: 530 kHz—1 710 kHz

AM 9 kHz intervals: 531 kHz—1 710 kHz

CD player

Dynamic range: 60 dB

Signal-to-noise ratio: 60 dB

Wow and flutter: Immeasurable

Cassette deck

Frequency response:

Normal (type I): 100 Hz—10 000 Hz

Wow and flutter: 0.35 % (WRMS)

General

Power requirement: AC 110 V–127 V/ 220 V–240 V \sim ,
adjustable with the voltage selector,
50 Hz/ 60 Hz

Power consumption: 22 W (at operation)
4.5 W (on standby)

Dimensions (W/H/D) (approx.):
145 mm x 209 mm x 226 mm

Mass (approx.): 2.6 kg

Supplied accessories

See page 6.

Speaker Section—SP-UXH10

Type: Full range bass-reflex type

Speakers: 10 cm cone x 1

Power handling capacity: 5 W

Impedance: 4 Ω

Frequency range: 100 Hz to 15 kHz

Dimensions (W/H/D) (approx.):
135 mm x 209 mm x 152 mm

Mass (approx.): 1.3 kg each

Mains (AC) Line Instruction (not applicable for Europe, U.S.A., Canada, Australia, and U.K.)

主（AC）电源线路说明（不适用于欧洲、美国、加拿大、澳洲及英国型号）

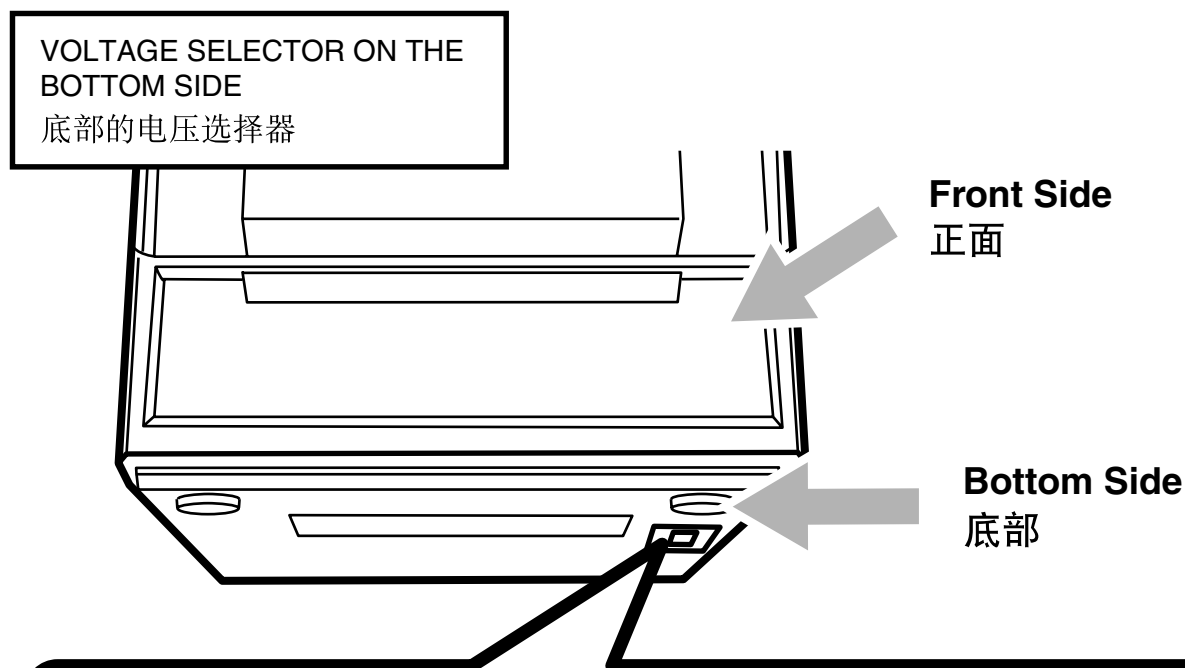

VOLTAGE SELECTOR

AC 220 - 2

AC 110 - 127V

IMPORTANT for mains (AC) line
BEFORE PLUGGING IN, do check that your mains (AC) line voltage corresponds with the position of the voltage selector switch provided on the outside of this equipment and, if different, reset the voltage selector switch, to prevent from a damage or risk of fire/electric shock.

有关主（AC）电源线路的重要事项
接插电源以前，务请检查当地的主（AC）电源线路电压是否和位于本机外面的电压选择开关设定的位置一致。如果不一致，即重新设定电压选择开关使符合当地电压，以免损坏机器或引起火灾／触电的危险。

The diagram shows a hand adjusting the voltage selector switch. The switch has two positions: 'AC 220 - 2' and 'AC 110 - 127V'. The text emphasizes the importance of checking the voltage before plugging in to prevent damage or fire.

JVC
VICTOR COMPANY OF JAPAN, LIMITED

JVC



English

Español

Português

MICRO COMPONENT SYSTEM SISTEMAS DE MICROCOMPONENTES SISTEMA DE MICRO COMPONENTES

UX-H10

—Consists of CA-UXH10 and SP-UXH10

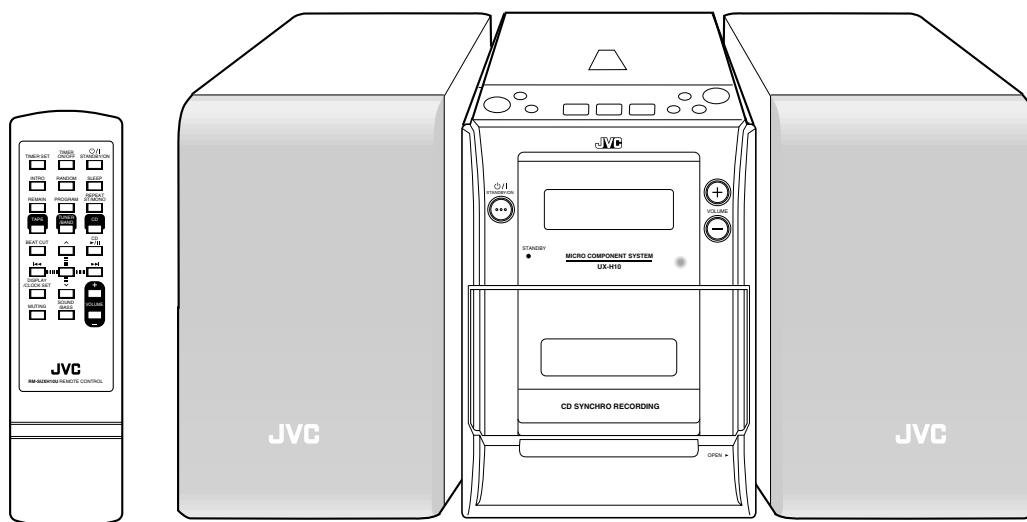

COMPACT
disc
DIGITAL AUDIO

INSTRUCTIONS MANUAL DE INSTRUCCIONES INSTRUÇÕES

LVT1092-009A
[UW]

Warnings, Cautions and Others

Avisos, precauciones y otras notas

Advertências, precauções e outras notas

CAUTION—/I STANDBY/ON button !

Disconnect the mains plug to shut the power off completely (all lamps and indications go off). The /I STANDBY/ON button in any position does not disconnect the mains line.

- When the unit is on standby, the STANDBY lamp lights red.
- When the unit is turned on, the STANDBY lamp goes off.

The power can be remote controlled.

PRECAUCIÓN—Botón /I STANDBY/ON !

Desconecte el enchufe tomacorriente para desconectar la alimentación completamente (se apagan todas las lámparas e indicaciones).

Ninguna posición del botón /I STANDBY/ON conseguirá desconectar la red de alimentación eléctrica.

- Cuando la unidad está en espera, la lámpara STANDBY se enciende en rojo.
- Cuando la unidad está encendida, la lámpara STANDBY se apaga.

La alimentación puede controlarse mediante control remoto.

CUIDADO—botão /I STANDBY/ON !

Desligue a ficha da tomada da parede para desligar completamente a alimentação (todas as luzes e indicadores apagam-se). O botão /I STANDBY/ON, quer esteja premido ou solto, não desliga a alimentação principal.

- Quando a unidade estiver em standby, a luz STANDBY fica vermelha.
- Quando a unidade estiver ligada, a luz STANDBY apaga-se.

A alimentação pode ser controlada à distância.

CAUTION

To reduce the risk of electrical shocks, fire, etc.:

1. Do not remove screws, covers or cabinet.
2. Do not expose this appliance to rain or moisture.

PRECAUCIÓN

Para reducir riesgos de choques eléctricos, incendio, etc.:

1. No extraiga los tornillos, las cubiertas ni la caja.
2. No exponga este aparato a la lluvia o a la humedad.

PRECAUÇÃO

Para reduzir riscos de choques elétricos, incêndio, etc.:

1. Não remova parafusos e tampas ou desmonte a caixa.
2. Não exponha este aparelho à chuva nem à umidade.

CAUTION

- Do not block the ventilation openings or holes. (If the ventilation openings or holes are blocked by a newspaper or cloth, etc., the heat may not be able to get out.)
- Do not place any naked flame sources, such as lighted candles, on the apparatus.
- When discarding batteries, environmental problems must be considered and local rules or laws governing the disposal of these batteries must be followed strictly.
- Do not expose this apparatus to rain, moisture, dripping or splashing and that no objects filled with liquids, such as vases, shall be placed on the apparatus.

PRECAUCIÓN

- No obstruya las rendijas o los orificios de ventilación. (Si las rendijas o los orificios de ventilación quedan tapados con un periódico, un trozo de tela, etc., no se podrá disipar el calor).
- No ponga sobre el aparato ninguna llama al descubierto, como velas encendidas.
- Cuando tenga que descartar las pilas, tenga en cuenta los problemas ambientales y observe estrictamente los reglamentos o las leyes locales sobre disposición de las pilas.
- No exponga este aparato a la lluvia, humedad, goteos o salpicaduras. Tampoco ponga recipientes conteniendo líquidos, como floreros, encima del aparato.

PRECAUÇÃO

- Não obstrua as aberturas e orifícios de ventilação. (Se os orifícios ou aberturas de ventilação estiverem obstruídos por qualquer papel ou tecido, não haverá circulação do ar quente.)
- Não coloque nenhum objeto com chamas, como velas acesas, sobre o aparelho.
- Ao descartar as baterias, leve em consideração os problemas que possam ser causados ao meio ambiente e os regulamentos e leis locais e governamentais sobre recolhimento dessas baterias devem ser rigorosamente seguidos.
- Não exponha este aparelho à chuva, umidade, pingos ou esguichos de água, nem coloque em cima do mesmo qualquer tipo de recipiente que contenha líquidos, como por exemplo vasos.

CAUTION: Proper Ventilation

To avoid risk of electric shock and fire, and to prevent damage, locate the apparatus as follows:

- 1 Front:
No obstructions and open spacing.
- 2 Sides/ Top/ Back:
No obstructions should be placed in the areas shown by the dimensions below.
- 3 Bottom:
Place on a level surface. Maintain an adequate air path for ventilation by placing on a stand with a height of 10 cm or more.

PRECAUCIÓN: Ventilación correcta

Para evitar el riesgo de descargas eléctricas e incendio y prevenir posibles daños, instale el equipo en un lugar que cumpla los siguientes requisitos:

- 1 Parte frontal:
Sin obstrucciones, espacio abierto.
- 2 Lados/parte superior/parte posterior:
No debe haber ninguna obstrucción en las áreas mostradas por las dimensiones de la siguiente figura.
- 3 Parte inferior:
Sitúe el equipo sobre una superficie nivelada. Mantenga un espacio adecuado para permitir el paso del aire y una correcta ventilación, colocando el equipo sobre un soporte de 10 cm o más de altura.

PRECAUÇÃO: Ventilação adequada

Para evitar riscos de choques elétricos e incêndios, e prevenir avarias, instale o aparelho como segue:

- 1 Parte frontal:
Sem obstruções e espaços abertos.
- 2 Partes laterais/ Tampa/ Posterior:
Nenhuma obstrução deverá ser colocada entre as áreas cujas dimensões são indicadas abaixo.
- 3 Parte inferior:
Instale-o sobre uma superfície plana. Deverá ser mantido espaço suficiente para a ventilação se este for instalado numa posição que tenha uma altura de 10 cm ou mais.

Front view
Vista frontal
Vista frontal

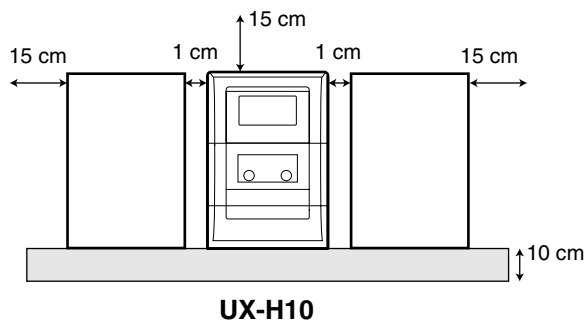

Side view
Vista lateral
Vista lateral

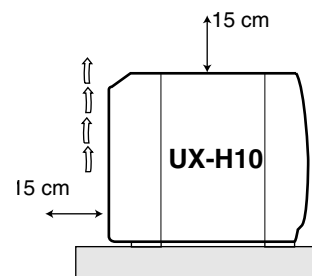

**IMPORTANT FOR LASER PRODUCTS
IMPORTANTE PARA PRODUCTOS LÁSER
IMPOTANTE PARA PRODUTOS LASER**

**REPRODUCTION OF LABELS
REPRODUCCIÓN DE ETIQUETAS
REPRODUÇÃO DE ETIQUETAS**

- | | |
|--|--|
| ① CLASSIFICATION LABEL ON EXTERIOR SURFACE | ② WARNING LABEL INSIDE THE UNIT |
| ① ETIQUETA DE CLASIFICACION SOBRE LA SUPERFICIE EXTERIOR | ② ETIQUETA DE ADVERTENCIA DEL INTERIOR DE LA UNIDAD |
| ① ETIQUETA DE CLASSIFICAÇÃO LOCALIZADA NA SUPERFÍCIE EXTERNA | ② ETIQUETA DE ADVERTÊNCIA LOCALIZADA NA PARTE INTERNA DA UNIDADE |

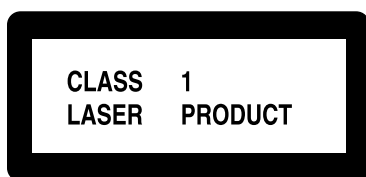

CAUTION: Invisible laser radiation when open and interlock failed or defeated. AVOID DIRECT EXPOSURE TO BEAM. (e)

ADVARSEL: Usynlig laserstråling ved åbning, når sikkerhedsafbrydere er ude af funktion. Undgå udsættelse for stråling (d)

WARNING: Osynlig laserstråling när denna del är öppnad och spärren är urkopplad. Betrakta ej strålen. (s)

VARO: Avattaessa ja suojalukitus ohitettaessa olet alttiina näkymättömälle lasersäteilylle. Älä katso säteeseen. (f)

1. CLASS 1 LASER PRODUCT
2. **CAUTION:** Invisible laser radiation when open and interlock failed or defeated. Avoid direct exposure to beam.
3. **CAUTION:** Do not open the top cover. There are no user serviceable parts inside the unit; leave all servicing to qualified service personnel.

1. PRODUCTO LÁSER CLASE 1
2. **PRECAUCIÓN:** En el interior hay radiación láser invisible. Evite el contacto directo con el haz.
3. **PRECAUCIÓN:** No abra la tapa superior. En el interior de la unidad no existen piezas reparables por el usuario; deje todo servicio técnico en manos de personal calificado.

1. PRODUTO LASER CLASSE 1
2. **CUIDADO:** O laser emite uma radiação invisível que é perigosa, caso o aparelho esteja aberto e a trava inoperante ou danificada. Evite exposição direta ao feixe dos raios.
3. **CUIDADO:** Não abra a caixa do aparelho. Não existem peças reparáveis pelo usuário na parte interna da unidade. Solicite assistência técnica somente a pessoal técnico qualificado.

Introduction

We would like to thank you for purchasing one of our JVC products. Before operating this unit, read this manual carefully and thoroughly to obtain the best possible performance from your unit, and retain this manual for future reference.

About This Manual

This manual is organized as follows:

- **This manual mainly explains operations using the buttons on the remote control. You can use the buttons both on the remote control and on the unit for the same operations if they have the same or similar names (or marks), unless mentioned otherwise.**
- Basic and common information that is the same for many functions is grouped in one place, and is not repeated for each procedure. For instance, we do not repeat the information about turning on/off the unit, setting the volume, changing the sound effects, and others, which are explained in the section “Basic and Common Operations” on pages 8 and 9.
- The following symbols are used in this manual:



Gives you warning and caution to prevent damage or risk of fire/electric shock. In addition, we put information here about conditions which will prevent getting the best possible performance from the unit.



Gives you information and hints you need to know.

Precautions

Installation

- Install in a place which is level, dry and neither too hot nor too cold—between 5°C and 35°C.
- Install the unit in a location with adequate ventilation to prevent internal heat buildup.
- Leave sufficient distance between the unit and the TV.
- Keep the speakers away from the TV to avoid interference with TV.



DO NOT install the unit in a location near heat sources, or in a place subject to direct sunlight, excessive dust or vibration.

Power sources

- When unplugging the unit from the wall outlet, always pull on the plug, not the AC power cord.



DO NOT handle the AC power cord with wet hands.

Moisture condensation

Moisture may condense on the lenses inside the unit in the following cases:

- After starting to heat the room.
- In a damp room.
- If the unit is brought directly from a cold to a warm place. Should this occur, the unit may malfunction. In this case, leave the unit turned on for a few hours until the moisture evaporates, unplug the AC power cord, then plug it in again.

Others

- Should any metallic object or liquid fall into the unit, unplug the AC power cord and consult your dealer before operating any further.
- If you are not going to operate the unit for an extended period of time, unplug the AC power cord from the wall outlet.



DO NOT disassemble the unit since there are no user serviceable parts inside.

If anything goes wrong, unplug the AC power cord and consult your dealer.

Location of the Buttons and Controls	3
Main Unit	3
Remote Control	5
Getting Started	6
Unpacking	6
Putting the Batteries into the Remote Control	6
Connections	6
Adjusting the Voltage Selector	7
Basic and Common Operations	8
Setting the Clock	8
Turning On the Power	8
Selecting the Source	9
Adjusting the Volume	9
Selecting the Sound Modes	9
Reinforcing the Bass Sound	9
Listening to FM and AM Broadcasts	10
Setting the Tuner Interval Spacing	10
Tuning in to a Station	10
Presetting Stations	11
Tuning in to a Preset Station	11
Playing Back Discs	12
Playing Back the Entire Disc—Normal Play	12
Basic Disc Operations	13
Programming the Track Playing Order	
—Program Play	13
Playing at Random—Random Play	14
Repeating Tracks—Repeat Play	14
Playing only Introductions—Intro Play	14
Displaying the Remaining Time during Playback	14
Playing Back Tapes	15
Playing Back a Tape	15
Recording	16
Recording from the Radio	16
Recording Discs	
—Disc Synchronized Recording	17
Using the Timers	18
Using the Daily Timer	18
Using the Sleep Timer	19
Maintenance	20
Troubleshooting	21
Specifications	22

Location of the Buttons and Controls

Become familiar with the buttons and controls on your unit.

Main Unit

Top view

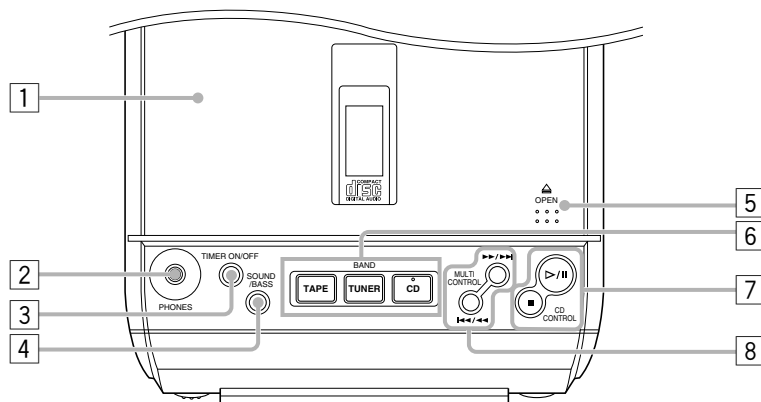

Front view

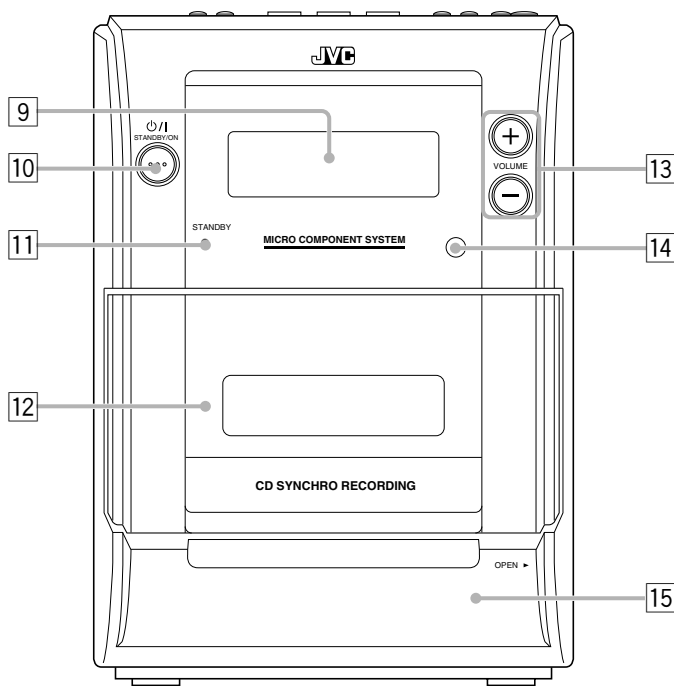

Inside the front cover

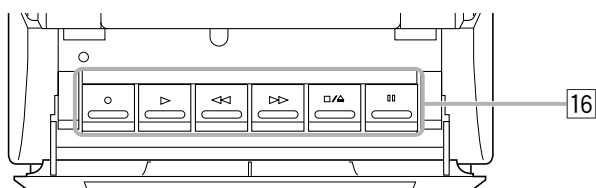

Display window on the front panel

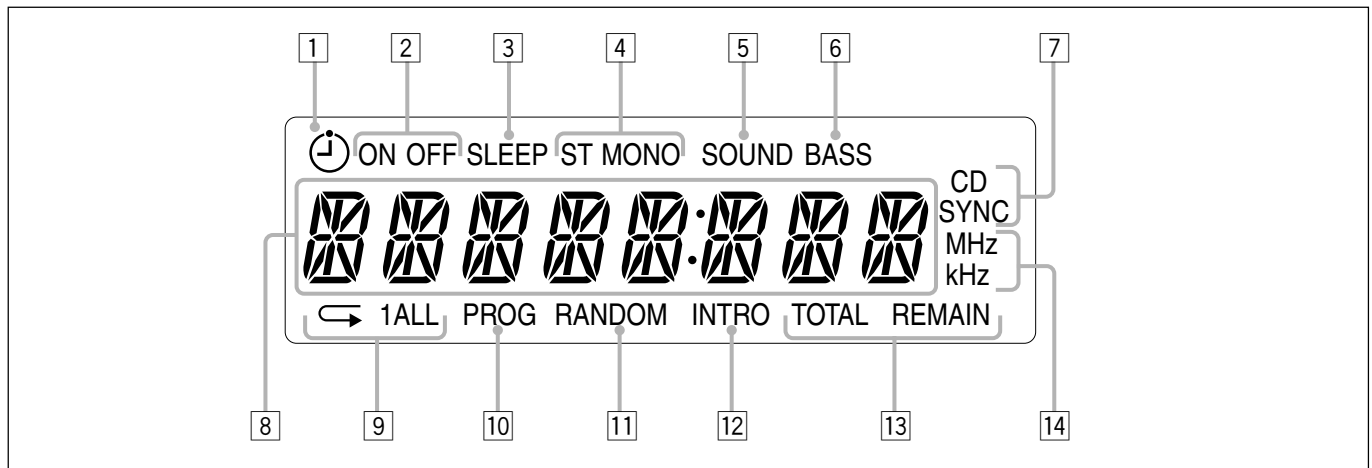

See pages in parentheses for details.

Main unit

- 1 Disc cover (12)
- 2 PHONES jack (9)
- 3 TIMER ON/OFF button (8, 19)
- 4 SOUND/BASS button (9)
- 5 ▲ OPEN (disc cover open) (12, 13)
- 6 Source buttons
 - TAPE, TUNER/BAND, CD*Pressing one of these buttons also turns on the unit.*
- 7 CD CONTROL buttons (8, 11, 12, 13)
 - ▷/||, ■
- 8 MULTI CONTROL buttons
 - ►►/►►, ◀◀/◀◀
- 9 Display window
- 10 ⏻/⏻ STANDBY/ON button (8, 11, 19)
- 11 STANDBY lamp (8)
- 12 Cassette holder (15)
- 13 VOLUME + / - buttons (9)
- 14 Remote sensor (5)
- 15 Front cover (15)
- 16 Tape operation buttons (15 – 17)
 - ○ (recording), ▷ (play), ◀◀ (fast backward),
 - ▷▷ (fast forward), ◻/⏻ (stop/cassette holder open),
 - ◻◻ (pause)

Display window

- 1 ⏻ (timer) indicator
- 2 ON/OFF (timer on-time/off-time) indicators
- 3 SLEEP indicator
- 4 FM mode indicators
 - ST (stereo), MONO
- 5 SOUND indicator
- 6 BASS indicator
- 7 CD SYNC (syncro) indicator
- 8 Main display
 - Shows the source name and other information.
- 9 Repeat indicators
 - ◀, 1, ALL
- 10 PROG (program) indicator
- 11 RANDOM indicator
- 12 INTRO indicator
- 13 Time indicators
 - TOTAL, REMAIN
- 14 Frequency indicators
 - MHz, kHz

To open the front cover

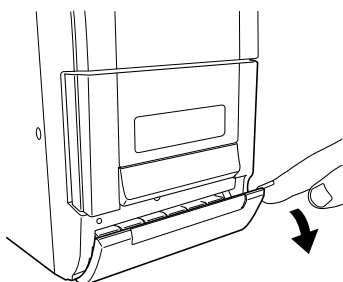

Remote Control

See pages in parentheses for details.

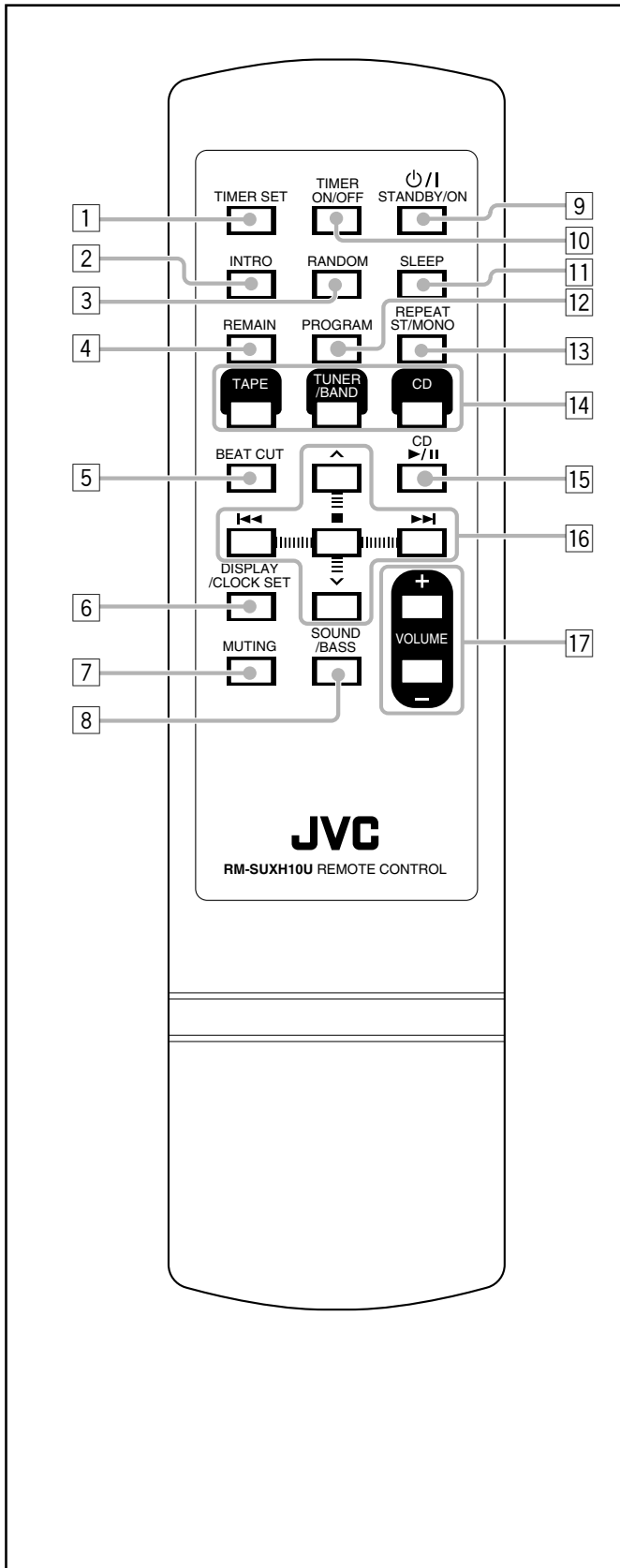

- 1 TIMER SET button (18, 19)
- 2 INTRO button (14)
- 3 RANDOM button (14)
- 4 REMAIN button (14)
- 5 BEAT CUT button (10, 16)
- 6 DISPLAY/CLOCK SET button (8)
- 7 MUTING button (9)
- 8 SOUND/BASS button (9)
- 9 O/I STANDBY/ON button (8, 19)
- 10 TIMER ON/OFF button (19)
- 11 SLEEP button (19)
- 12 PROGRAM button (8, 11, 13, 18, 19)
- 13 REPEAT ST/MONO button (10, 14)
- 14 Source buttons
 - TAPE, TUNER/BAND, CD

Pressing one of these buttons also turns on the unit.
- 15 CD $\blacktriangleright/\parallel$ button (12, 13)
- 16 Multi control buttons
 - \wedge, \vee
 - $\blacktriangleleft, \blacksquare, \blacktriangleright$
- 17 VOLUME + / - buttons (9)

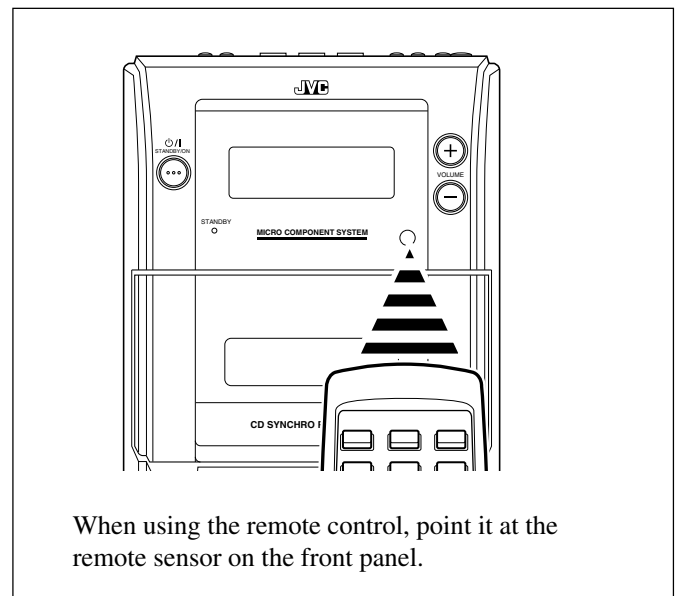

Unpacking

After unpacking, check to be sure that you have all the following items.

The number in parentheses indicates the quantity of each piece supplied.

- AM loop antenna (1)
- Remote control (1)
- Batteries (2)
- AC plug adaptor (1)

If any item is missing, consult your dealer immediately.

Putting the Batteries into the Remote Control

Insert the batteries—R03(UM-4)/AAA(24F)—into the remote control by matching the polarity (+ and -) on the batteries with the + and - marking on the battery compartment.

When the remote control can no longer operate the unit, replace both batteries at the same time.

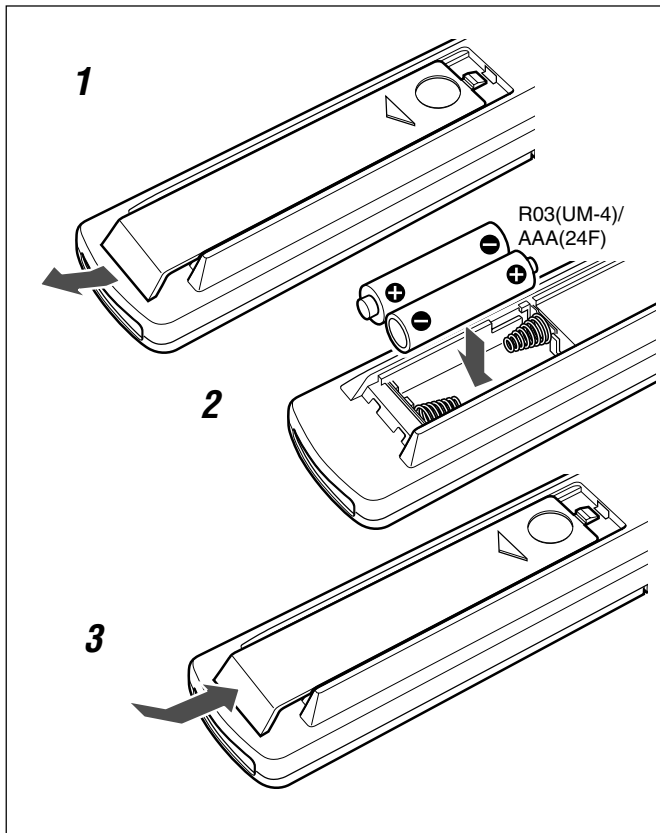

- DO NOT use an old battery together with a new one.
- DO NOT use different types of batteries together.
- DO NOT expose batteries to heat or flame.
- DO NOT leave the batteries in the battery compartment when you are not going to use the remote control for an extended period of time. Otherwise, the remote control will be damaged from battery leakage.

Connections

To connect speakers

You can connect the speakers using the speaker cords.

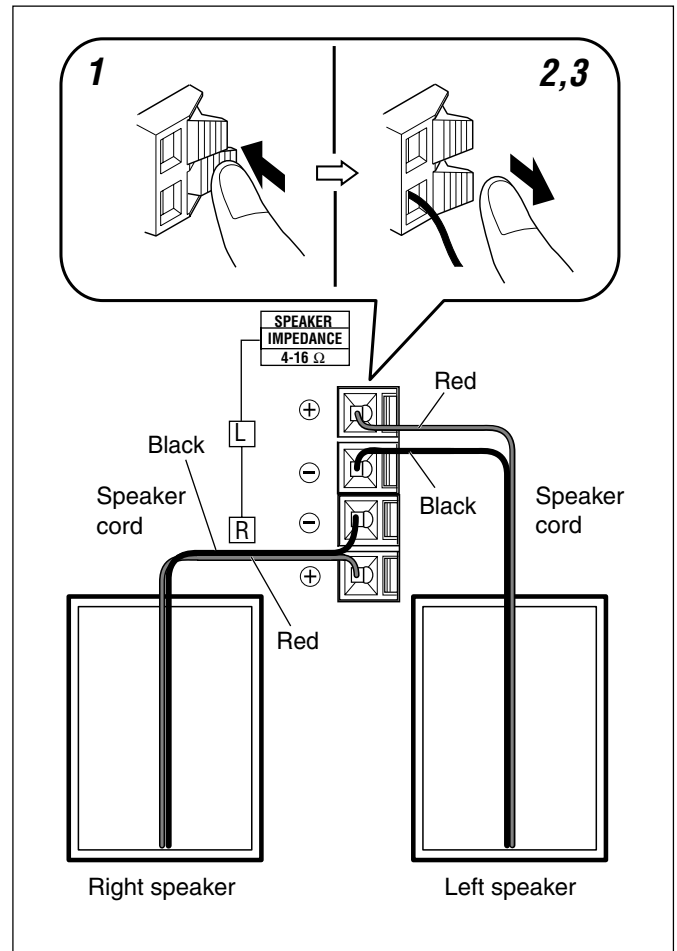

1 Hold the clamp of the speaker terminal.

2 Insert the end of the speaker cord into the terminal.

Match the polarity of the speaker terminals: red (+) to red (+) and black (-) to black (-).

3 Release your finger from the clamp.

IMPORTANT:

- Use only speakers with the same speaker impedance as indicated by the speaker terminals on the rear of the unit.
- DO NOT connect more than one speaker to one speaker terminal.

To connect AM and FM antennas

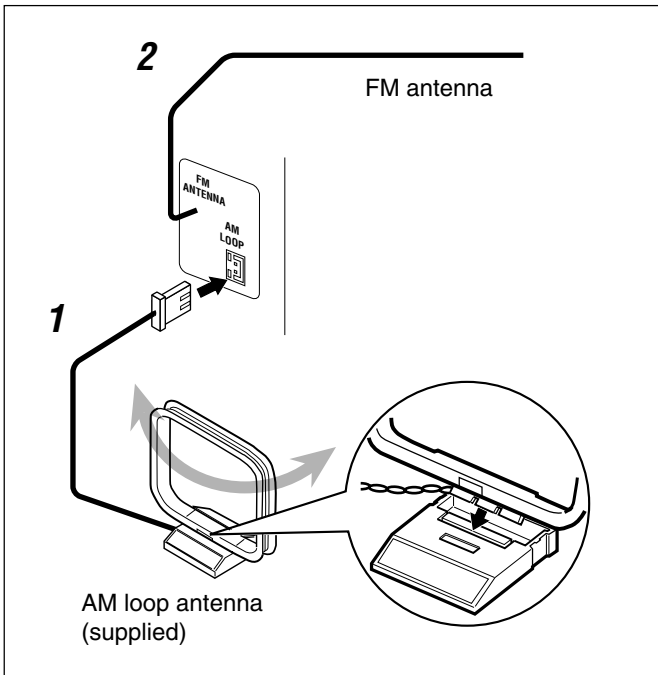

1 Connect the supplied AM loop antenna to the AM LOOP terminal.

Place the antenna away from the unit and adjust its position for the best reception.

2 Adjust the position for the FM antenna for the best reception.



For better reception of both FM and AM

- Make sure the antenna conductors do not touch any other terminals or connecting cords.
- Keep the antennas away from metallic parts of the unit, connecting cords, and the AC power cord.

Adjusting the Voltage Selector

Before plugging in the unit, set the correct voltage for your area with the voltage selector on the bottom of the unit.

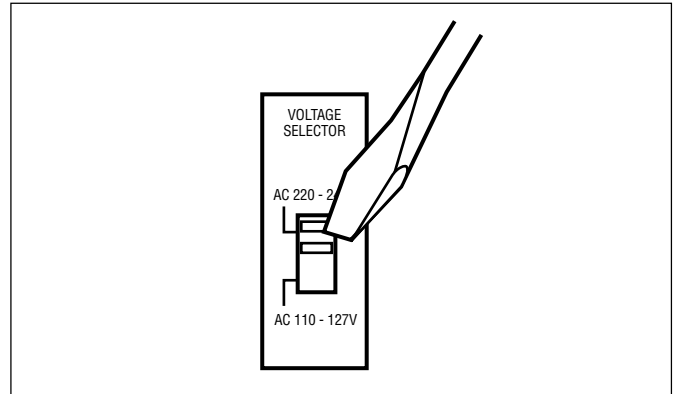

Use a screwdriver to move the voltage selector so the voltage number is the same as the voltage where you are plugging in the unit. (See the back cover page.)



- DO NOT plug in before setting the voltage selector on the bottom of the unit and all connection procedures are complete.
- DO NOT drag the unit when moving it. Dragging may possibly change the voltage selector setting accidentally.

NOW you are ready to plug in the unit.

- If the wall outlet does not match the AC plug, use the supplied AC plug adaptor.

IMPORTANT:

Be sure to check that all connections have been made before plugging in the power cord.

Setting the Clock

Before operating the unit any further, first set the unit's clock. When you plug in the power cord, "0:00" starts flashing on the display.

You can set the clock when the unit is either turned on or in standby mode.



- In the following procedure, the clock is set to 24-hour system.

On the remote control ONLY:



1 When the unit is in standby mode, press and hold PROGRAM until the hour indication starts flashing.



- When the unit is on, press DISPLAY/CLOCK SET to enter clock mode, then press and hold PROGRAM.

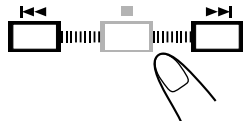

2 Press  or  to adjust the hour, then press PROGRAM.



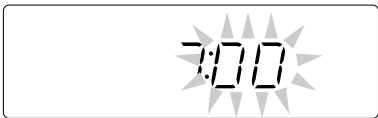

- When you press and hold  or , the hour indication changes continuously.

The minute indication start flashing.

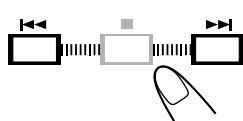

3 Press  or  to adjust the minute, then press PROGRAM.



- When you press and hold  or , the minute indication changes continuously.

The built-in clock starts.

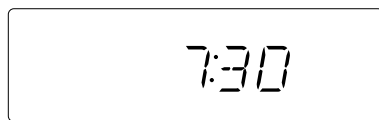

- **When you unplug the AC power cord or if a power failure occurs**
The clock is reset to "0:00" right away. If this happens, set the clock again.
- **The clock may gain or lose 1 to 2 minutes per month**
If this happens, reset the clock.

To select 12-hour or 24-hour clock system

You can select 12-hour or 24-hour for the clock system only while the unit is in standby mode.

On the unit ONLY:

To change the clock setting, press TIMER ON/OFF while holding down .

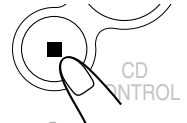

- Each time you press TIMER ON/OFF, the clock change alternates between 12-hour and 24-hour system.

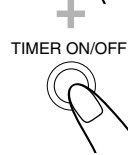

To show the clock when the unit is turned on

On the remote control ONLY:

Press DISPLAY/CLOCK SET.

- Each time you press the button, the display changes the clock indication and the normal indication alternately.

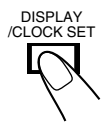

To change the clock

Repeat steps 1 to 3 of the procedure "Setting the Clock."

Turning On the Power

To turn on the unit, press /STANDBY/ON. The STANDBY lamp on the unit goes off.



- When you press the source button—TAPE, TUNER/BAND and CD, the unit automatically turns on.

To turn off the unit (standby), press /STANDBY/ON again. The STANDBY lamp on the unit lights red.

- "0:00" flashes on the display until you set the built-in clock. After setting the clock, the clock time will appear on the display while the unit is on standby.
- A little power is always consumed even while the unit is in standby mode.

To switch off the power supply completely, unplug the AC power cord from the AC outlet.



- **When you unplug the AC power cord or if a power failure occurs**
The clock is reset to "0:00" right away. If this happens, set the clock again.

Selecting the Source

To select the source, press TAPE, TUNER/BAND, or CD.

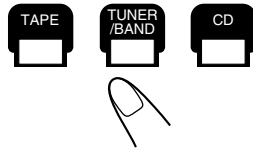

- When you select TAPE or CD as the source, playback does not start automatically.

To operate the tuner (FM or AM), see pages 10 and 11.

To operate the CD player, see pages 12 – 14.

To operate the tape deck, see page 15.

To record on a tape, see pages 16 and 17.

Adjusting the Volume

You can adjust the volume level only while the unit is turned on. The volume level can be adjusted between “VOL MIN,” “VOL 1” – “VOL 39,” and “VOL MAX.”

- The volume level has no effect on recording.

To increase the volume, press VOLUME +.

To decrease the volume, press VOLUME –.

- When you press and hold either button, you can change the volume level continuously.

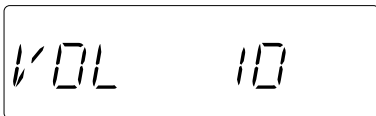

To turn off the sound temporarily

On the remote control ONLY:

Press **MUTING**.

The volume level turns down and “MUTING” starts flashing on the display.



To restore the sound, press **MUTING** again.

- Adjusting the volume level also cancels the muting.



For private listening

Connect a pair of headphones to the PHONES jack. No sound comes out of the speakers. Be sure to turn down the volume before connecting or putting on the headphones.



DO NOT turn off (standby) the unit with the volume set to an extremely high level; Otherwise, the sudden blast of sound can damage your hearing, speakers and/or headphones when you turn on the unit or start playing any source. REMEMBER you cannot adjust the volume level while the unit is in standby mode.

Selecting the Sound Modes

You can select one of the 4 sound modes.

- This function also affects the sound from headphones.
- This function only affects the playback sound, and does not affect your recording.

To select the sound modes, press **SOUND/BASS** repeatedly.

- Each time you press the button, the sound mode changes as follows:



POP: More presence in the vocals and midrange.

CLASSIC: Enriched sound with fine treble and ample bass.

ROCK: Powerful sound emphasizing treble and bass.

JAZZ: Accented lower frequencies for jazz-type music.

FLAT: Equalizer effect is canceled.

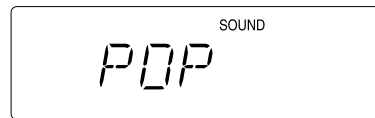

When the sound mode is activated, the **SOUND** indicator lights up on the display.

Reinforcing the Bass Sound

The richness and fullness of the bass sound is clearly maintained regardless of how low you set the volume—Hyper Bass Sound.

- This function also affects the sound from headphones.
- This function only affects the playback sound, and does not affect your recording.

To get the effect, press and hold **SOUND/BASS** until “HBS ON” appears and the **BASS** indicator lights up on the display.

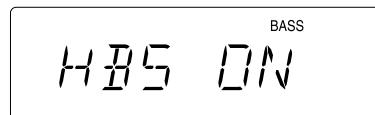

- Each time you press and hold the button, the effect alternates (“HBS ON”) and off (“HBS OFF”).

To cancel the effect, press and hold **SOUND/BASS** again until “HBS OFF” appears and the **BASS** indicator goes off.

Listening to FM and AM Broadcasts

Setting the Tuner Interval Spacing

You can select 10 kHz or 9 kHz apart for the AM tuner interval spacing and 100 kHz or 50 kHz apart for the FM tuner interval spacing.

- You need to do this setting separately for each band.

On the unit ONLY:

1 Press TUNER/BAND to select either “FM” or “AM.”

The unit automatically turns on and tunes in to the previously received station—either FM or AM.

- Each time you press the button, the band alternates between FM and AM.



2 Press \odot/I STANDBY/ON while holding down \blacksquare .

- Each time you press \odot/I STANDBY/ON, the interval spacing alternates as follows:

While selecting the AM tuner

10K (10 kHz) \leftrightarrow 9K (9 kHz)

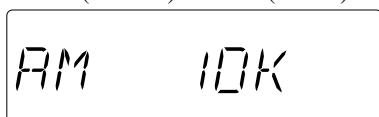

While selecting the FM tuner

100K (100 kHz) \leftrightarrow 50K (50 kHz)

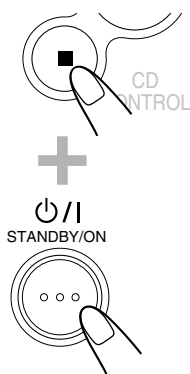

When you change the setting

The preset stations are erased. You will need to preset the stations again. (See page 11.)

Tuning in to a Station

1 Press TUNER/BAND to select either “FM” or “AM.”

The unit automatically turns on and tunes in to the previously received station—either FM or AM.

- Each time you press the button, the band alternates between FM and AM.

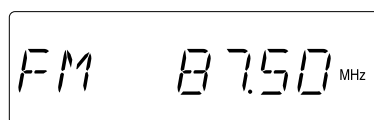

2 Press and hold $\blacktriangleright\blacktriangleright$ or $\blacktriangleleft\blacktriangleleft$ (or $\blacktriangleright/\blacktriangleright$ or $\blacktriangleleft/\blacktriangleleft$ on the unit) for more than 1 second.

- $\blacktriangleright\blacktriangleright$ ($\blacktriangleright/\blacktriangleright$): Increases the frequencies.
- $\blacktriangleleft\blacktriangleleft$ ($\blacktriangleleft/\blacktriangleleft$): Decreases the frequencies.

The unit starts searching for stations and stops when a station of sufficient signal strength is tuned in.

- If an FM program is broadcast in stereo, the ST (stereo) indicator lights up on the display (only when the reception is good).

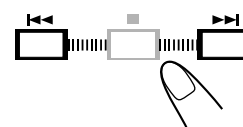

To stop during searching, press $\blacktriangleright\blacktriangleright$ or $\blacktriangleleft\blacktriangleleft$ (or $\blacktriangleright/\blacktriangleright$ or $\blacktriangleleft/\blacktriangleleft$ on the unit).



When you repeatedly press $\blacktriangleright\blacktriangleright$ or $\blacktriangleleft\blacktriangleleft$ (or $\blacktriangleright/\blacktriangleright$ or $\blacktriangleleft/\blacktriangleleft$ on the unit)

The frequency changes step by step.

To change the FM reception mode

On the remote control ONLY:

When an FM stereo broadcast is hard to receive or noisy, press REPEAT ST/MONO so that the MONO indicator lights up on the display. Reception will improve.



To restore the stereo effect, press REPEAT ST/MONO again so that the MONO indicator goes off. In stereo mode, you can hear stereo sound when a stereo program is broadcast.

To reduce the beat—Beat Cut

On the remote control ONLY:

If the beats are heard while listening a broadcast, press BEAT CUT.



Presetting Stations

You can preset 20 FM and 20 AM stations manually.

In some cases, test frequencies have been already stored for the tuner since the factory examined the tuner preset function before shipment. This is not a malfunction. You can preset the stations you want into memory by following the presetting method.

- There is a time limit in doing the following steps. If the setting is canceled before you finish, start again from step 2.

On the remote control ONLY:

1 Tune in to the station you want to preset.

- See “Tuning in to a Station” on page 10.

2 Press PROGRAM.

The PROG (program) indicator and “00” start flashing on the display.



3 Press ^ or v to select a preset number.

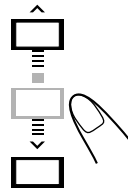
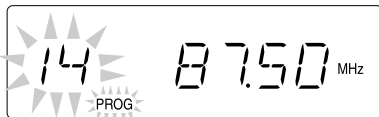

4 Press PROGRAM again.

The PROG indicator and the selected preset number stop flashing.



5 To preset more stations, repeat steps 1 to 4 above, allocating a different preset number to each station.

- Storing a new station on an already assigned number erases the previously stored one.



When you unplug the AC power cord or if a power failure occurs

The preset stations will remain in the unit.

Tuning in to a Preset Station

On the remote control ONLY:

1 Press TUNER/BAND to select either “FM” or “AM.”

The unit automatically turns on and tunes in to the previously received station—either FM or AM.

- Each time you press the button, the band alternates between FM and AM.



2 Press ^ or v to select a preset number.

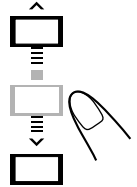

This unit has been designed to play back the following discs—CD, CD-R, and CD-RW.

When playing a CD-R or CD-RW

User-edited CD-Rs (CD-Recordable) and CD-RWs (CD-ReWritable) can be played only if they are already “finalized.”

- Usually you can play back your original CD-Rs or CD-RWs recorded in music CD format. However, sometimes they may not play depending on their characteristics or recording conditions.
- Before playing CD-Rs or CD-RWs, read their instructions or cautions carefully.
- Some CD-Rs or CD-RWs may not play on this unit because of their disc characteristics, damage or stain on them, or if the player’s lens is dirty.
- CD-RWs may require a longer readout time. This is because the reflectance of CD-RWs is lower than for regular discs.

General notes

- In general, you will have the best performance by keeping your discs and the mechanism clean.
- Store discs in their cases, and keep them in cabinets or on shelves.
 - Keep the unit’s disc trays closed when not in use.

Continued use of irregular shape discs (heart-shape, octagonal, etc.) can damage the unit.



Playing Back the Entire Disc—Normal Play

1 Press OPEN on the unit.

- The disc cover opens.
- You can insert a disc while listening to another source.

2 Place a disc correctly with its label side up.

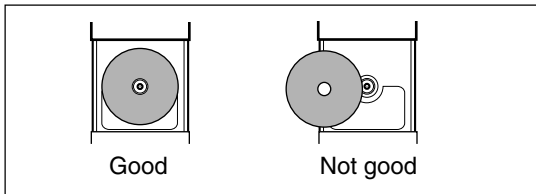

3 Close the disc cover gently.

4 Press CD.

The unit automatically turns on and the source changes to the CD player. After loading the disc, total track number and total playing time appear on the display.

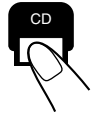

Total track number Total playing time

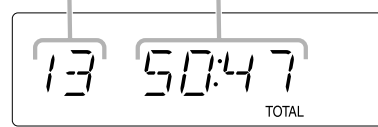

5 Press CD .

The first track of the disc starts playing.



Current track number



Elapsed playing time

- The disc automatically stops when the last track has finished playing.

To stop playing, press .

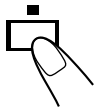

To remove the disc, press  OPEN on the unit.



- If the disc cannot be read correctly (because it is scratched, for example) or an unreadable CD-R or CD-RW is inserted Playback will not start.
- If no disc is inserted “NO DISC” appears on the display.

 DO NOT try to open the disc cover by hand as it will be damaged.

Basic Disc Operations

While playing a disc, you can do the following operations.

To stop playing for a moment

During play, press CD ►/||.

While pausing, the elapsed playing time flashes on the display.



To resume playing, press CD ►/|| again.

To go to another track

Before or during play, press ►► or ◀◀ repeatedly.

- ►►: Skips to the beginning of the next or succeeding tracks.
- ◀◀: Goes back to the beginning of the current or previous tracks.

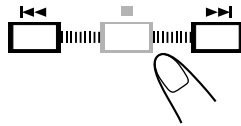

To locate a particular point in a track

During play, press and hold ►► or ◀◀.

- ►►: Fast-forwards the tracks.
- ◀◀: Fast-reverses the tracks.

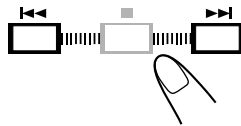

Programming the Track Playing Order —Program Play

You can arrange the order in which tracks play before you start playing. You can program up to 60 tracks.

On the remote control ONLY:

1 Place a disc.

- If the current source is not the CD player, press CD.

2 Press PROGRAM.

The PROG (program) indicator starts flashing on the display.

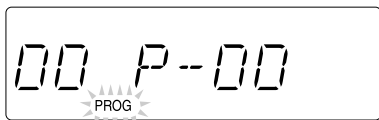

- If a program has been stored in memory, the program is called up.

3 Press ►► or ◀◀ to select the track number, then press PROGRAM.

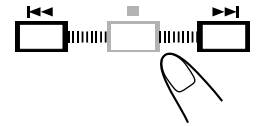

Track number Program step number

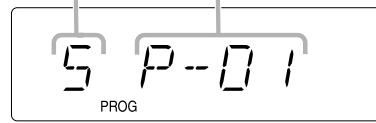

4 Repeat step 3 to program other tracks you want.

5 Press CD ►/||.

The tracks are played in the order you have programmed.



If you try to program a 61st track "FULL" will appear on the display.

To stop playing, press ■.

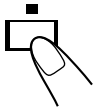

To check the program contents

Press PROGRAM repeatedly in stop mode. The program number and track number are displayed in succession.



To modify the program

Press PROGRAM repeatedly in stop mode to select the number which you want to change the track, then repeat step 3 above.



To clear the program

Press ■ in stop mode.

The PROG indicator disappears from the display.

- Pressing ▲ OPEN to open the disc cover will also erase the programmed tracks.

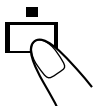

Playing at Random—Random Play

You can play the tracks at random.

On the remote control ONLY:

Press **RANDOM** before or during playing.

The **RANDOM** indicator lights up on the display.

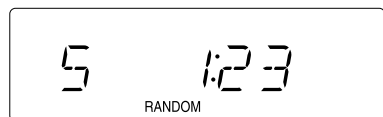

To exit from **Random Play**, press **RANDOM** again. The **RANDOM** indicator goes off.



- It is not possible to activate the random play function during Program Play.

Repeating Tracks—Repeat Play

You can have all the tracks, the program or individual track currently playing, repeat as many times as you like.

On the remote control ONLY:

Press **REPEAT ST/MONO** repeatedly before or during playing.

- Each time you press the button, Repeat Play changes as follows, and the following repeat indicator lights up on the display:

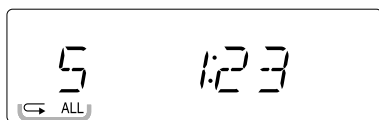
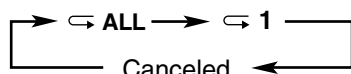

Repeat indicators

- ↶ **ALL**: In Normal Play, repeats all the tracks. In Program Play, repeats all the tracks in the program. In Random Play, repeats all the tracks in random order.
- ↶ **1**: Repeats one track.

To cancel **Repeat Play**, press **REPEAT ST/MONO** repeatedly until the repeat indicator goes off.



- Repeat Play remains in effect even when you select another play mode (Normal, Program, Random, or Intro Play).
- In Random Play, ↶ 1 cannot be selected. If ↶ 1 has been selected when you press **RANDOM**, it is canceled.
- If you select ↶ 1 in Random Play, Random Play is canceled.

Playing only Introductions—Intro Play

You can play only the introductions of the tracks.

On the remote control ONLY:

Press **INTRO**.

The **INTRO** indicator lights up and the first 10-second portion of each track is played back in order.



To cancel **Intro Play**, press **INTRO** again. The **INTRO** indicator goes off.

- Intro Play remains in effect even when you select another play mode (Program or Random Play).

Displaying the Remaining Time during Playback

You can display the remaining time of the current track/disc and the elapsed time of the current track/disc during playing.

On the remote control ONLY:

Press **REMAIN** repeatedly.

- Each time you press the button, the display changes as follows, and the following indicators light up on the display:

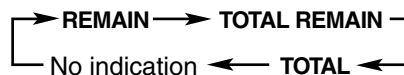

- REMAIN**: Shows the remaining time of the current track.
- TOTAL REMAIN**: Shows the remaining time and track number of the disc.
- TOTAL**: Shows the elapsed time of the disc.
- No indication**: Shows the elapsed time of the current track.

Playing Back Tapes

For Tape operations, use buttons inside the front cover on the unit.

Playing Back a Tape

You can play back type I tapes only.

On the unit ONLY:

1 Open the front cover.

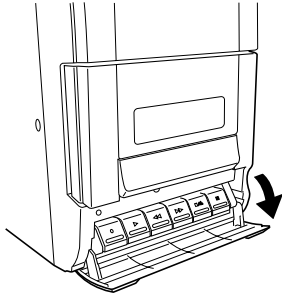

2 Press □/△ (stop/cassette holder open).

The cassette holder opens.

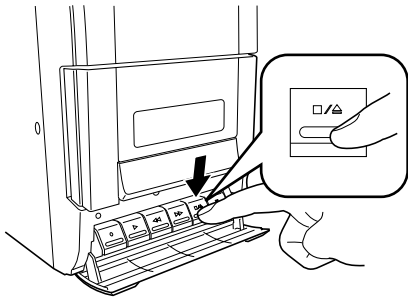

3 Put a cassette in with the exposed part of the tape down.

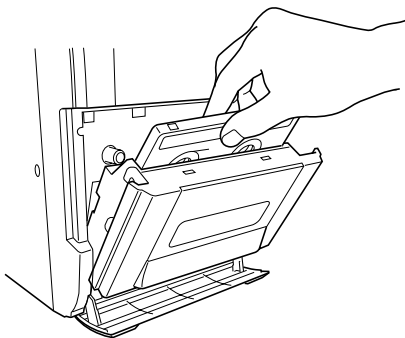

4 Close the cassette holder gently.

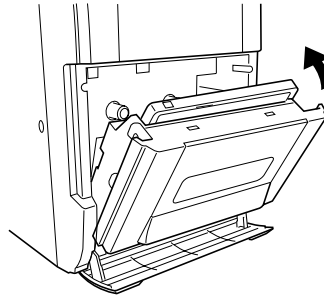

5 Press TAPE.

The unit automatically turns on and the source changes to the tape deck.

- You can select to the tape by pressing TAPE on the remote control.



6 Press ▷ (play).

The tape starts playing.

- When the end of the tape is reached, playing stops.

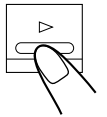

To stop playing, press □/△.

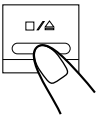

To stop playing for a moment, press || (pause).
To resume playing, press || again.

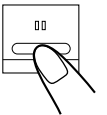

To fast forward or rewind the tape, press ▷▷ or ◁◁.

- The tape stops at the end of the fast forwarding or rewinding. To release the locked button, press □/△.

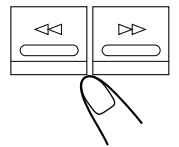

To remove the cassette, press □/△ while playback is stopped.

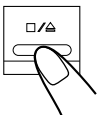

- DO NOT turn off the unit while playing back or recording a tape. The cassette deck or tapes may be damaged.
- The use of C-120 or longer tape is not recommended, since characteristic deterioration may occur and this tape easily jams in the pinch rollers and the capstans.
- This unit is not compatible with type II and type IV tapes.

IMPORTANT:

- It may be unlawful to record or play back copyrighted material without the consent of the copyright owner.
- The recording level is automatically set correctly, so it is not affected by the other sound settings. Thus, during recording you can adjust the sound you are actually listening to without affecting the recording level.
- If recordings you have made have excessive noise or static, the unit may be too close to a TV. Increase the distance between the TV and the unit.
- You can only use type I tape for recording.



- DO NOT turn off the unit while playing back or recording a tape. The cassette deck or tapes may be damaged.
- DO NOT use type II and type IV tapes since the unit is not compatible with such tapes.
- The use of C-120 or longer tape is not recommended, since characteristic deterioration may occur and this tape easily jams in the pinch rollers and the capstans.



At the start and end of cassette tapes

There is leader tape which cannot be recorded onto. Thus, when recording from discs, FM/AM broadcasts, or external equipment, wind the leader tape first to ensure that the recording will be made without losing any music.

To protect your recordings

Cassettes have two small tabs on the back to protect against unexpected erasure or re-recording.

To protect your recording, remove these tabs.

To re-record on a protected tape, cover the holes with adhesive tape.

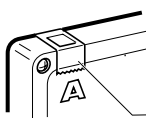

Adhesive tape

Recording from the Radio

On the unit ONLY:

1 Put a recordable cassette in with the exposed part of the tape down.

- See also page 15.

2 Close the cassette holder gently.

3 Press TUNER/BAND to select either “FM” or “AM.”

- When recording from discs, see “Recording Discs—Disc Synchronized Recording” on page 17.

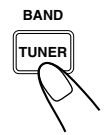

4 Tune in to the station you want to record.

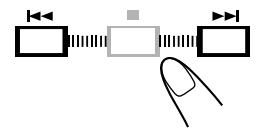

5 Press ○ (recording).

- ○ and ▷ lock down, and the recording starts.

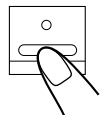

You cannot press ○ in the following cases:

- If no cassette is inserted.
- If a protected tape is inserted.

To stop recording for a moment, press ||| (pause).

To resume recording, press ||| again.

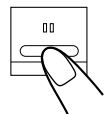

To stop recording, press □/△.

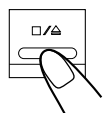

To remove the cassette, press □/△ while recording is stopped.



To record an AM station—Beat Cut

On the remote control ONLY:

While recording an AM broadcast, beats may be heard (which are never heard when listening to the broadcast without recording it).

If this occurs, press BEAT CUT repeatedly, while recording, until the beats are reduced.

- Each time you press the button, the display changes alternates “BEAT 01” and “BEAT 02.”



Recording Discs

—Disc Synchronized Recording

You can start disc play and recording at the same time.

On the unit ONLY:

1 Put a recordable cassette in with the exposed part of the tape down.

- See also page 15.

2 Close the cassette holder gently.

3 Press CD select the CD player as the source.

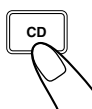

4 Press \circ (recording).

The CD SYNC indicator appears on the display and the CD starts playback automatically and the recording starts.

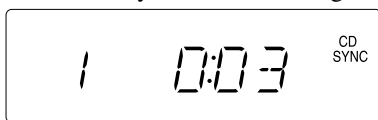
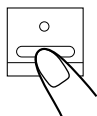

- When the end of the tape is reached, recording stops and the CD player is paused.
- If you press \circ while playing back the CD, the CD player return to the beginning of that track and the track is recorded on the tape.



You cannot press \circ in the following cases:

- If no cassette is inserted.
- If a protected tape is inserted.

To stop recording for a moment, press \square .

The recording is paused, but the CD playback does not stop.

To resume recording, press \square again.

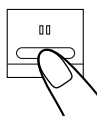

To stop recording, press \square/\triangle .

The recording stops and the CD playback is paused.



To remove the cassette, press \square/\triangle while recording is stopped.

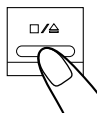

Daily Timer and Sleep Timer are available.

- Before using these timers, make sure the built-in clock is set correctly (see page 8).

Using the Daily Timer

You can set the Daily Timer when the unit is either turned on or in standby mode.

How the Daily Timer actually works

When the on-time comes, the unit automatically turns on and then the off-time comes, the unit automatically turns off (standby).

- Once the timer has been set, it will be activated at the same time everyday until the timer is turned off and the timer setting remains in memory until you change it.

Before you start...

When using "TUNER" as the source to play, make sure to select the desired station before turning off the power.

- In the following procedure, the clock is set to 24-hour system.
- There is a time limit in doing the following steps. If the setting is canceled before you finish, start again from step 1.

On the remote control ONLY:

1 Press TIMER SET.



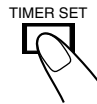

The  (timer) and the ON (on-time) indicators flash and the on-time setting appears on the display.

If you does not need to change the on-time setting, go to step 3.



2 Press PROGRAM to set the on-time you want the unit to turn on.

The hour indication starts flashing on the display.

- 1) Press  or  to set the hour, then press PROGRAM.
- 2) Press  or  to set the minute, then press PROGRAM.

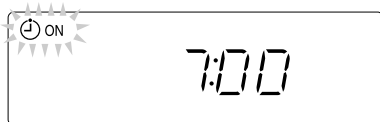
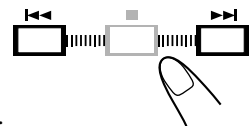

3 Press TIMER SET.

The  (timer) and the OFF (off-time) indicators flash and the off-time setting appears on the display.



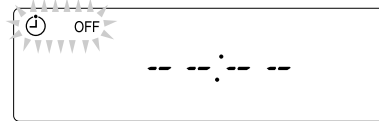

If you does not need to change the off-time setting, go to step 5.

- If you change the on-time setting, the off-time setting changes to "--:--". You need to set the off-time setting.



4 Press PROGRAM to set the off-time you want the unit to turn off.

The hour indication starts flashing on the display.

- 1) Press  or  to set the hour, then press PROGRAM.
- 2) Press  or  to set the minute, then press PROGRAM.

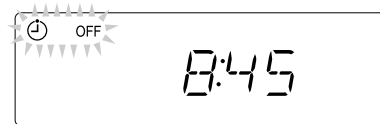
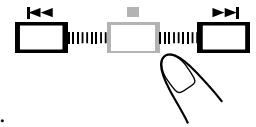

5 Press TIMER SET.

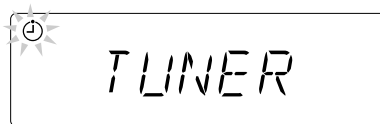

The  (timer) indicator flashes and the source name appears on the display.

If you does not need to change the source, go to step 7.



6 Press PROGRAM to select the source to play.

The source name starts flashing on the display.

- Press  or  to select "CD" or "TUNER," then press PROGRAM.

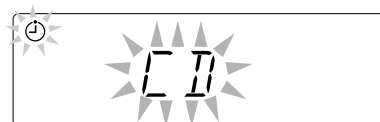
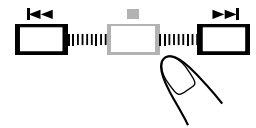

7 Press **TIMER SET**.

The display changes normal indication and exit the timer setting mode.



8 Press **TIMER ON/OFF** to activate the daily timer mode.

Each time you press the button, the Daily Timer alternates on and off.

While activating the Daily Timer, the ⏰ (timer) indicator lights up on the display.

- You can activate the Daily Timer by pressing **TIMER ON/OFF** on the unit.

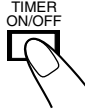

9 Press **⏻/| STANDBY/ON** to turn off the unit if the unit is on.

To deactivate the timer temporarily, press **TIMER ON/OFF** until the ⏰ (timer) indicator goes off.



To activate and change the timer, repeat steps **1** to **8** on pages 18 and 19.

- To activate the timer again without changing the setting, press **TIMER ON/OFF** until the ⏰ (timer) indicator lights up on the display.



If the unit is already turned on when the timer on-time comes

The timer does not work.



When you unplug the AC power cord or if a power failure occurs

The timer will be canceled. You need to set the clock first, then set the timer again.

Using the Sleep Timer

With the Sleep Timer, you can fall asleep to your favorite music or radio program.

- You can set the Sleep Timer only when the unit is turned on.

How the Sleep Timer actually works

The unit automatically turns off after the specified length of time passes.

On the remote control ONLY:

1 Press **SLEEP**.

The **SLEEP** indicator lights up on the display.



- Each time you press the button, the length of time changes as follows:

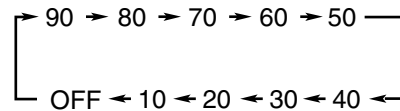

2 Wait for about 5 seconds after specifying the length of time.

To check the remaining time until shut-off time, press **SLEEP** once. The remaining time until shut-off time appears for about 5 seconds.

To change the shut-off time, press **SLEEP** repeatedly until the length of time you want appears.

To cancel the setting, press **SLEEP** repeatedly until "OFF" appears and the **SLEEP** indicator goes off on the display.

- Turning off the unit also cancels the Sleep Timer.



If you set the Sleep Timer after the Daily Timer starts playing the selected source

The Daily timer is canceled. The unit turns off when the Sleep Timer shut-off time comes.



If you set the Sleep Timer while playing back or recording a tape

Do not shut the unit off with the Sleep Timer while a tape is running. If the unit turns off while playing back or recording a tape, the cassette deck or tapes may be damaged.

Maintenance

To get the best performance of the unit, keep your discs, tapes and mechanism clean.

General Notes

In general, you will have the best performance by keeping your discs, tapes and the mechanism clean.

- Store discs and tapes in their cases, and keep them in cabinets or on shelves.

Cleaning the unit

• Stains on the unit

Should be wiped off with a soft cloth. If the unit is heavily stained, wipe it with a cloth soaked in water-diluted neutral detergent and wrung well, then wipe clean with a dry cloth.

- **Since the unit may deteriorate in quality, become damaged or have its paint peel off, be careful about the following:**
 - DO NOT wipe it with a rough cloth.
 - DO NOT wipe it too vigorously.
 - DO NOT wipe it with thinner or benzine.
 - DO NOT apply any volatile substance such as an insecticide to it.
 - DO NOT allow any rubber or plastic to remain in contact with it for a long time.

Handling discs



- Remove the disc from its case by holding it at the edge while pressing the center hole lightly.
- Do not touch the shiny surface of the disc, or bend the disc.
- Put the disc back in its case after use to prevent warping.

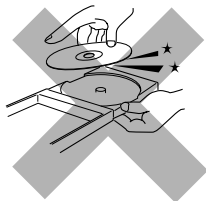

- Be careful not to scratch the surface of the disc when placing it back in its case.
- Avoid exposure to direct sunlight, temperature extremes, and moisture.

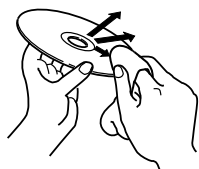

To clean the disc

Wipe the disc with a soft cloth in a straight line from center to edge.



DO NOT use any solvent—such as conventional record cleaner, spray, thinner, or benzine—to clean the disc.

Handling cassette tapes

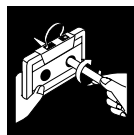

- If the tape is loose in its cassette, take up the slack by inserting a pencil in one of the reels and rotating.
- If the tape is loose, it may get stretched, cut, or caught in the cassette.



- Be careful not to touch the tape surface.



- Avoid storing tapes in any of the following places:
 - In dusty places
 - In direct sunlight or heat
 - In moist areas
 - On a TV or speaker
 - Near a magnet

To keep the best recording and playback sound quality

You need to clean the heads.

- Clean the heads after every 10 hours of use with a wet-type head cleaning tape (available at electronic and audio shops).
When the head becomes dirty, the following symptoms will occur:
 - Sound quality is reduced.
 - Sound level decreases.
 - Sound drops out.
- Do not play dirty or dusty tapes.
- Do not touch the highly-polished head with any metallic or magnetic tools.

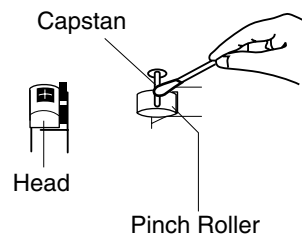

To demagnetize the head

Turn off the unit, and use a head demagnetizer (available at electronic and audio shops).

Troubleshooting

If you are having a problem with your unit, check this list for a possible solution before calling for service.

If you cannot solve the problem from the hints given here, or the unit has been physically damaged, call a qualified person, such as your dealer, for service.

Symptom	Possible Cause	Action
Power does not come on.	The power cord is not connected to an AC outlet.	Insert the plug into the socket.
No sound is heard.	<ul style="list-style-type: none"> • Connections are incorrect or loose. • A pair of headphones is connected. 	<ul style="list-style-type: none"> • Check all connections and make corrections. (See pages 6 and 7.) • Unplug the headphones from the PHONES jack.
Hard to listen to broadcasts because of noise.	<ul style="list-style-type: none"> • Antennas are disconnected. • The AM loop antenna is too close to the unit. • The FM antenna is not properly extended and positioned. 	<ul style="list-style-type: none"> • Reconnect the antenna correctly and securely. • Change the position and direction of the AM loop antenna. • Extend FM antenna and orient to the best reception position.
The disc does not play.	The disc is upside down.	Put the disc in with the label side up.
Impossible to record.	Small tabs on the back of the cassette are removed.	Cover the holes with adhesive tape.
Operations are disabled.	The built-in microprocessor has malfunctioned due to external electrical interference.	Unplug the AC power cord then plug it back in.
Unable to operate the unit by the remote control.	<ul style="list-style-type: none"> • The path between the remote control and the remote sensor on the unit is blocked. • The batteries are exhausted. • You are using the remote control too far from the unit. 	<ul style="list-style-type: none"> • Remove the obstruction. • Replace the batteries. (See page 6.) • Signals cannot reach the remote sensor. Move closer to the unit.

Amplifier Section—CA-UXH10

Output Power (IEC 268-3):

10 W (5 W + 5 W) at 4 Ω (10% THD)

Speakers/Impedance: 4 Ω – 16 Ω

Tuner

FM tuning range: 87.50 MHz—108.00 MHz

AM tuning range:

AM 10 kHz intervals: 530 kHz—1 710 kHz

AM 9 kHz intervals: 531 kHz—1 710 kHz

CD player

Dynamic range: 60 dB

Signal-to-noise ratio: 60 dB

Wow and flutter: Immeasurable

Cassette deck

Frequency response:

Normal (type I): 100 Hz—10 000 Hz

Wow and flutter: 0.35 % (WRMS)

General

Power requirement: AC 110 V–127 V/ 220 V–240 V \sim ,
adjustable with the voltage selector,
50 Hz/ 60 Hz

Power consumption: 22 W (at operation)
4.5 W (on standby)

Dimensions (W/H/D) (approx.):
145 mm x 209 mm x 226 mm

Mass (approx.): 2.6 kg

Supplied accessories

See page 6.

Speaker Section—SP-UXH10

Type: Full range bass-reflex type

Speakers: 10 cm cone x 1

Power handling capacity: 5 W

Impedance: 4 Ω

Frequency range: 100 Hz to 15 kHz

Dimensions (W/H/D) (approx.):
135 mm x 209 mm x 152 mm

Mass (approx.): 1.3 kg each

Mains (AC) Line Instruction (not applicable for Europe, U.S.A., Canada, Australia, and U.K.)

Instrucción sobre la línea de la red (CA) (no aplicable para Europa, EE.UU., Canadá, Australia, ni el Grã-Bretanha)

Instrução sobre a tensão da rede eléctrica (CA) (não aplicável para a Europa, os E.U.A., o Canadá, a Austrália e o Reino Unido)

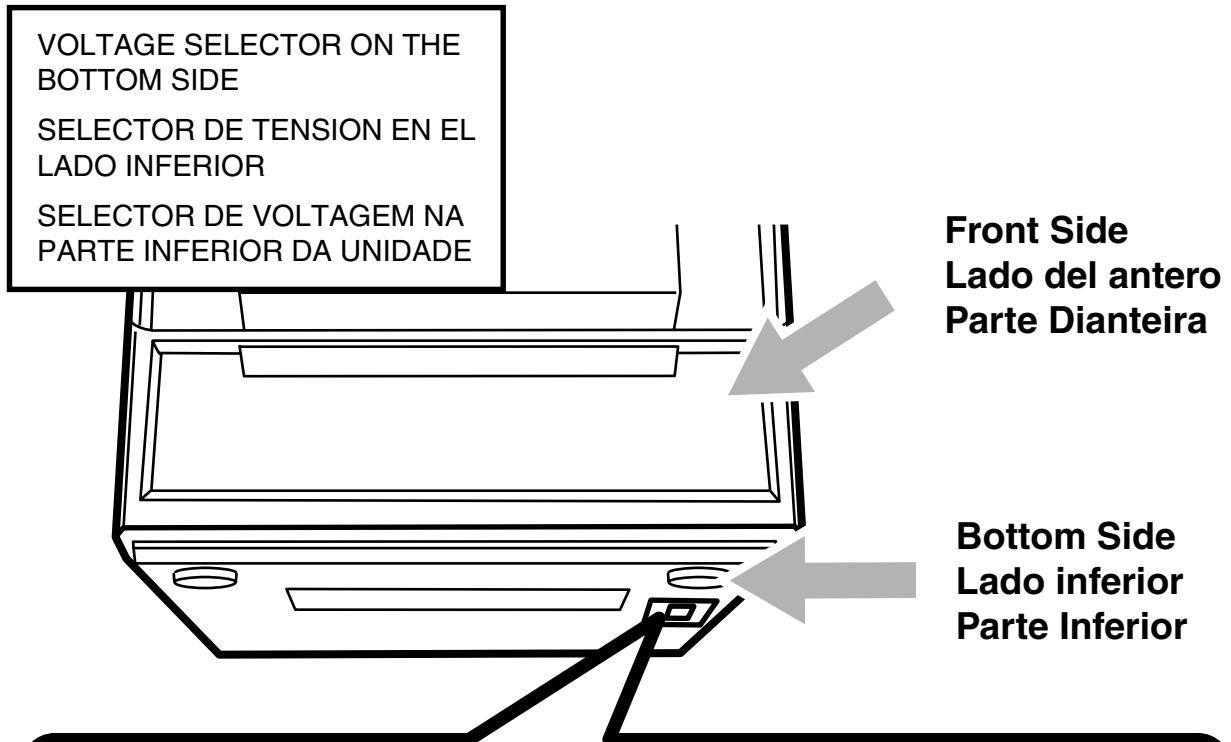

IMPORTANT for mains (AC) line
BEFORE PLUGGING IN, do check that your mains (AC) line voltage corresponds with the position of the voltage selector switch provided on the outside of this equipment and, if different, reset the voltage selector switch, to prevent from a damage or risk of fire/electric shock.

IMPORTANTE para la línea de la red (CA)
ANTES DE ENCHUFAR EL EQUIPO, compruebe si la tensión de la línea de la red a(CA) corresponde con la posición del selector de tensión situado en la parte exterior del equipo, y si es diferente, reajuste el selector de tensión para evitar el riesgo de incendios/ descargas eléctricas.

IMPORTANTE para a ligação à tensão da rede (CA)
ANTES DE LIGAR O APARELHO A UMA TOMADA DA REDE, verifique se a tensão da rede CA corresponde à posição do seletor de voltagem localizado na parte externa deste equipamento. Caso não corresponda, reajuste o seletor de voltagem a fim de evitar avarias ou riscos de incêndio e choque elétrico.

JVC
VICTOR COMPANY OF JAPAN, LIMITED